

# Installation – Parts List



ALUMINUM AND STAINLESS STEEL

# Husky™ 1590 Air-Operated Diaphragm Pumps

308441ZAK

EN

1.5-inch AODD pump for fluid transfer applications.  
For professional use only.

See Models on page 3 for a list of pump models and descriptions.

*120 psi (0.8 MPa, 8 bar) Maximum Fluid Working Pressure*

*120 psi (0.8 MPa, 8 bar) Maximum Air Input Pressure*



## Important Safety Instructions

Read all warnings and instructions in this manual. Save these instructions.

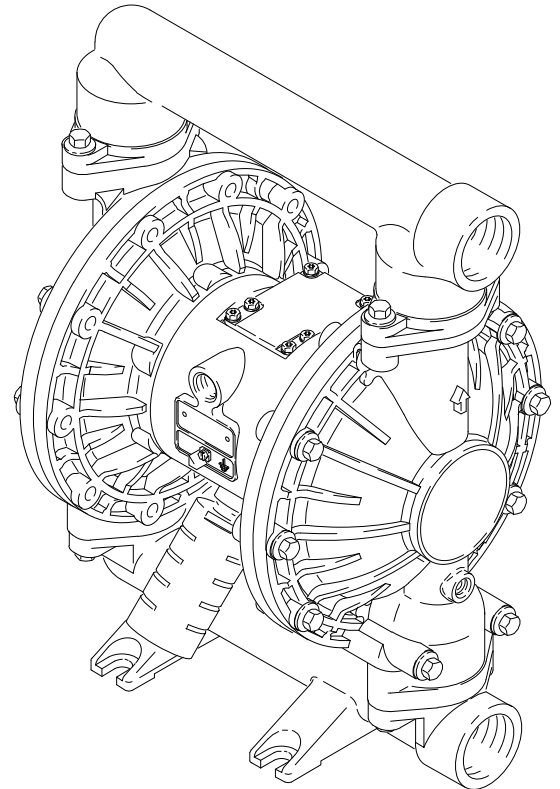

**Model No. DB3777 shown**

03263B



PROVEN QUALITY. LEADING TECHNOLOGY.

# Table of Contents

<b>Models</b> .....	3	<b>Pump Matrix</b> .....	24
<b>Symbols</b> .....	4	<b>Repair Kit Matrix</b> .....	26
<b>Installation</b> .....	6	<b>Parts Drawing</b> .....	27
<b>Operation</b> .....	12	<b>Parts</b> .....	28
<b>Maintenance</b> .....	13	<b>Torque Instructions</b> .....	31
<b>Troubleshooting</b> .....	14	<b>Dimensions</b> .....	32
<b>Service</b> .....	16	<b>Technical Data</b> .....	35
Repairing the Air Valve .....	16	<b>Performance Chart</b> .....	36
Ball Check Valve Repair .....	18	<b>Graco Standard Husky Pump Warranty</b> .....	38
Diaphragm Repair .....	19	<b>Graco Information</b> .....	38
Bearing and Air Gasket Removal .....	22		

# Models

Model No.	Description
*DB3_____	Aluminum Pumps
*DC3_____	Aluminum Pumps, Remote
*DB4_____	Stainless Steel Pumps
*DC4_____	Stainless Steel Pumps, Remote
*DBC_____	Aluminum BSPT Pumps
*DCC_____	Aluminum BSPT Pumps, Remote
*DBD_____	Stainless Steel BSPT Pumps
*DBP_____	Stainless Steel Pumps with Flanged Manifold Ports (Vertical Outlet)
*DBR_____	Stainless Steel Pumps with Flanged Manifold Ports (Horizontal Outlet)
*DCD_____	Stainless Steel BSPT Pumps, Remote
*DT4_____	Stainless Steel Plus Pumps
*DU4_____	Stainless Steel Plus Pumps, Remote
*DT7_____	Stainless Steel Pumps, Type 3.1 Certification
*DT8_____	Stainless Steel Pumps, Type 3.1-Advanced Certification
*DTD_____	Stainless Steel BSPT Plus Pumps
*DUD_____	Stainless Steel BSPT Plus Pumps, Remote
*DTP_____	Stainless Steel Pumps with Flanged Manifold Ports (Vertical Outlet)
*DTR_____	Stainless Steel Pumps with Flanged Manifold Ports (Horizontal Outlet)
253485	Aluminum Pump
232502	Private-Label Aluminum Pump
24B780	Stainless Steel Plus Pump with overmolded diaphragms
24B781	Stainless Steel Pump with overmolded diaphragms
24G411	Aluminum BSPT Pump with overmolded diaphragms
24J358	Aluminum Pump with overmolded diaphragms
24J359	Aluminum Pump with overmolded diaphragms
25A017	Aluminum Pump with overmolded diaphragms, SST balls
25C654	Stainless Steel Pump with SST Center Section, Flanged Manifold Ports (Horizontal Outlet), and overmolded diaphragms
25C655	Stainless Steel Pump with Aluminum Center Section, Flanged Manifold Ports (Horizontal Outlet), and overmolded diaphragms
25C656	Stainless Steel Pump with SST Center Section, Flanged Manifold Ports (Vertical Outlet), and overmolded diaphragms
25C657	Stainless Steel Pump with Aluminum Center Section, Flanged Manifold Ports (Vertical Outlet), and overmolded diaphragms

\* Refer to the Pump Matrix on page 24 to determine the Model No. of your pump.

**NOTE:** Plus Models include stainless steel center sections.

# Symbols

## Warning Symbol



This symbol alerts you to the possibility of serious injury or death if you do not follow the instructions.

## Caution Symbol



This symbol alerts you to the possibility of damage to or destruction of equipment if you do not follow the instructions.

## WARNING



### EQUIPMENT MISUSE HAZARD

Equipment misuse can cause the equipment to rupture or malfunction and result in serious injury.

- This equipment is for professional use only.
- Read all instruction manuals, tags, and labels before operating the equipment.
- Use the equipment only for its intended purpose. If you are not sure, call your Graco distributor.
- Do not alter or modify this equipment. Use only genuine Graco parts and accessories.
- Check equipment daily. Repair or replace worn or damaged parts immediately.
- Do not exceed the maximum working pressure of the lowest rated component in your system. This equipment has a 120 psi (0.8 MPa, 8 bar) maximum working pressure at **120 psi (0.8 MPa, 8 bar) maximum incoming air pressure**.
- Use fluids and solvents which are compatible with the equipment wetted parts. Refer to the **Technical Data** section of all equipment manuals. Read the fluid and solvent manufacturer's warnings.
- Do not use 1,1,1-trichloroethane, methylene chloride, other halogenated hydrocarbon solvents or fluids containing such solvents in pressurized aluminum equipment. Such use could result in a chemical reaction, with the possibility of explosion.
- Do not use hoses to pull equipment.
- Route hoses away from traffic areas, sharp edges, moving parts, and hot surfaces. Do not expose Graco hoses to temperatures above 82°C (180°F) or below -40°C (-40°F).
- Do not lift pressurized equipment.
- Comply with all applicable local, state, and national fire, electrical, and safety regulations.

# WARNING



## TOXIC FLUID HAZARD

Hazardous fluid or toxic fumes can cause serious injury or death if splashed in the eyes or on the skin, inhaled, or swallowed.

- Know the specific hazards of the fluid you are using.
- Store hazardous fluid in an approved container. Dispose of hazardous fluid according to all local, state and national guidelines.
- Always wear protective eyewear, gloves, clothing and respirator as recommended by the fluid and solvent manufacturer.
- Pipe and dispose of the exhaust air safely, away from people, animals, and food handling areas. If the diaphragm fails, the fluid is exhausted along with the air. See **Air Exhaust Ventilation** on page 11.



## FIRE AND EXPLOSION HAZARD

Improper grounding, poor ventilation, open flames or sparks can cause a hazardous condition and result in a fire or explosion and serious injury.

- Ground the equipment. Refer to **Installation** on page 7.
- If there is any static sparking or you feel an electric shock while using this equipment, **stop pumping immediately**. Do not use the equipment until you identify and correct the problem.
- Provide fresh air ventilation to avoid the buildup of flammable fumes from solvents or the fluid being sprayed.
- Pipe and dispose of the exhaust air safely, away from all sources of ignition. If the diaphragm fails, the fluid is exhausted along with the air. See **Air Exhaust Ventilation** on page 11.
- Keep the work area free of debris, including solvent, rags, and gasoline.
- Electrically disconnect all equipment in the work area.
- Extinguish all open flames or pilot lights in the work area.
- Do not smoke in the work area.
- Do not turn on or off any light switch in the work area while operating or if fumes are present.
- Do not operate a gasoline engine in the work area.

# Installation

## General Information

- The typical installation shown in FIG. 1 is only a guide for selecting and installing system components. Contact your Graco distributor for assistance in planning a system to suit your needs.
- Always use Genuine Graco Parts and Accessories. Refer to Product Data Sheet 305646.
- Reference numbers and letters in parentheses refer to the callouts in the figures and the parts lists on pages 27-28.
- Lift the pump by grasping the outlet manifold (1) securely. See FIG. 3 on page 10.

## WARNING



Hazardous fluid or toxic fumes can cause serious injury or death if splashed in the eyes or on the skin, inhaled, or swallowed.

1. Read **TOXIC FLUID HAZARD** on page 5.
2. Use fluids and solvents which are compatible with the equipment wetted parts. Refer to the **Technical Data** section of all equipment manuals. Read the fluid and solvent manufacturer's warnings.

## Tightening Screws Before First Use

Before using the pump for the first time, check and retorque all external fasteners. See **Torque Instructions**, page 31. After the first day of operation, retorque the fasteners. Although pump use varies, a general guideline is to retorque fasteners every two months.

## Tips to Reduce Cavitation

Cavitation in a diaphragm pump is the formation and collapse of bubbles in the pumped liquid. Frequent or excessive cavitation can cause serious damage, including pitting and early wear of fluid chambers, balls, and seats. It may result in reduced efficiency of the pump. Cavitation damage and reduced efficiency both result in increased operating costs.

Cavitation depends on the vapor pressure of the pumped liquid, the system suction pressure, and the velocity pressure. It can be reduced by changing any of these factors.

1. Reduce vapor pressure: Decrease the temperature of the pumped liquid.
2. Increase suction pressure:
  - a. Lower the installed position of the pump relative to the liquid level in the supply.
  - b. Reduce the friction length of the suction piping. Remember that fittings add friction length to the piping. Reduce the number of fittings to reduce the friction length.
  - c. Increase the size of the suction piping.  
**NOTE:** Be sure the inlet fluid pressure does not exceed 25 % of the outlet working pressure.
3. Reduce liquid velocity: Slow the cyclic rate of the pump.

Pumped liquid viscosity is also very important but normally is controlled by factors that are process dependent and cannot be changed to reduce cavitation. Viscous liquids are more difficult to pump and more prone to cavitation.

Graco recommends taking all the above factors into account in system design. To maintain pump efficiency, supply only enough air pressure to the pump to achieve the required flow.

Graco distributors can supply site specific suggestions to improve pump performance and reduce operating costs.

## Grounding

## WARNING



### FIRE AND EXPLOSION HAZARD

This pump must be grounded. Before operating the pump, ground the system as explained below. Also, read the section **FIRE AND EXPLOSION HAZARD**, on page 5.



To reduce the risk of static sparking, ground the pump and all other equipment used or located in the pumping area. Check your local electrical code for detailed grounding instructions for your area and type of equipment. **Ground all of this equipment:**

# Installation

- **Pump:** Connect a ground wire and clamp as shown in FIG. 1. Loosen the grounding screw (W). Insert one end of a 12 ga (1.5 mm<sup>2</sup>) minimum ground wire (Y) behind the grounding screw and tighten the screw securely. Connect the clamp end of the ground wire to a true earth ground. Order Part No. 222011 Ground Wire and Clamp.

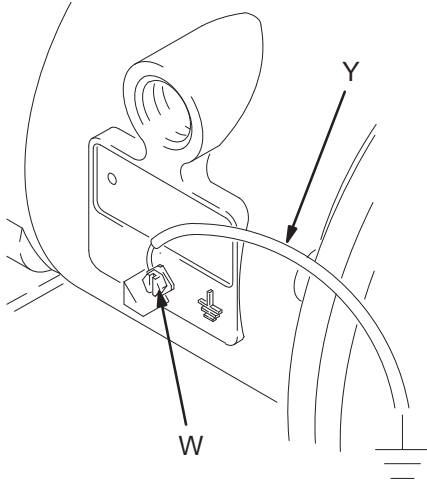

02646B

FIG. 1

- **Air and fluid hoses:** Use only grounded hoses with a maximum of 500 ft (150 m) combined hose length to ensure grounding continuity.
- **Air compressor:** Follow the manufacturer's recommendations.
- **All solvent pails used when flushing:** Follow the local code. Use only metal pails, which are conductive. Do not place the pail on a non-conductive surface, such as paper or cardboard, which interrupts the grounding continuity.
- **Fluid supply container:** Follow the local code.

## Mountings

### ⚠ CAUTION

The pump exhaust air may contain contaminants. Ventilate to a remote area if the contaminants could affect your fluid supply. See **Air Exhaust Ventilation** on page 11.

1. Be sure the mounting surface can support the weight of the pump, hoses, and accessories, as well as the stress caused during operation.

2. For all mountings, be sure the pump is bolted directly to the mounting surface.
3. For ease of operation and service, mount the pump so the air valve cover (2), air inlet, and fluid inlet and outlet ports are easily accessible.
4. Rubber Foot Mounting Kit 236452 is available to reduce noise and vibration during operation.

## Air Line

### ⚠ WARNING

A bleed-type master air valve (B) is required in your system to relieve air trapped between this valve and the pump. Trapped air can cause the pump to cycle unexpectedly, which could result in serious injury, including splashing in the eyes or on the skin, injury from moving parts, or contamination from hazardous fluids. See FIG. 2.

1. Install the air line accessories as shown in FIG. 2. Mount these accessories on the wall or on a bracket. Be sure the air line supplying the accessories is grounded.
  - a. Install an air regulator (C) and gauge to control the fluid pressure. The fluid outlet pressure will be the same as the setting of the air regulator.
  - b. Locate one bleed-type master air valve (B) close to the pump and use it to relieve trapped air. See the **WARNING** above. Locate the other master air valve (E) upstream from all air line accessories and use it to isolate them during cleaning and repair.
  - c. The air line filter (F) removes harmful dirt and moisture from the compressed air supply.
2. Install a grounded, flexible air hose (A) between the accessories and the 1/2 npt(f) pump air inlet (N). See FIG. 3. Use a minimum 1/2 in. (13 mm) ID air hose. Screw an air line quick disconnect coupler (D) onto the end of the air hose (A), and screw the mating fitting into the pump air inlet snugly. Do not connect the coupler (D) to the fitting until you are ready to operate the pump.

# Installation

## Installation of Remote Pilot Air Lines

1. Refer to Parts Drawing. Connect air line to pump as in preceding steps.
2. Connect 1/4 in. O.D. tubing to push type connectors (14) on air motor of pump.

**NOTE:** by replacing the push type connectors, other sizes or types of fittings may be used. The new fittings will require 1/8 in. npt threads.

3. Connect remaining ends of tubes to external air signal, such as Graco's Cycleflo (P/N 195264) or Cycleflo II (P/N195265) controllers.

**NOTE:** the air pressure at the connectors must be at least 30% of the air pressure to the air motor for the pump to operate.

## Fluid Suction Line

1. **Use grounded fluid hoses (G).** The pump fluid inlet (R) is 1-1/2 in. npt(f). Screw the fluid fitting into the pump inlet securely.
2. If the fluid inlet pressure to the pump is more than 25% of the outlet working pressure, the ball check valves will not close fast enough, resulting in inefficient pump operation.

3. At inlet fluid pressures greater than 15 psi (0.1 MPa, 1 bar), diaphragm life will be shortened.
4. See the **Technical Data** on page 35 for maximum suction lift (wet and dry).

## Fluid Outlet Line

### **WARNING**

A fluid drain valve (J) is required to relieve pressure in the hose if it is plugged. The drain valve reduces the risk of serious injury, including splashing in the eyes or on the skin, or contamination from hazardous fluids when relieving pressure. Install the valve close to the pump fluid outlet. See FIG. 2.

1. **Use grounded fluid hoses (L).** The pump fluid outlet (S) is 1-1/2 in. npt(f). Screw the fluid fitting into the pump outlet securely.
2. Install a fluid drain valve (J) near the fluid outlet. See the **WARNING** above.
3. Install a shutoff valve (K) in the fluid outlet line.



## TYPICAL FLOOR-MOUNT INSTALLATION

### KEY

- A Air supply hose
- B Bleed-type master air valve (required for pump)
- C Air regulator
- D Air line quick disconnect
- E Master air valve (for accessories)
- F Air line filter
- G Fluid suction hose
- H Fluid supply
- J Fluid drain valve (required)
- K Fluid shutoff valve
- L Fluid hose
- R Fluid inlet port
- S Fluid outlet port
- Y Ground wire (required; see page 5 for installation instructions)

Muffler not included  
on Model No. 253485

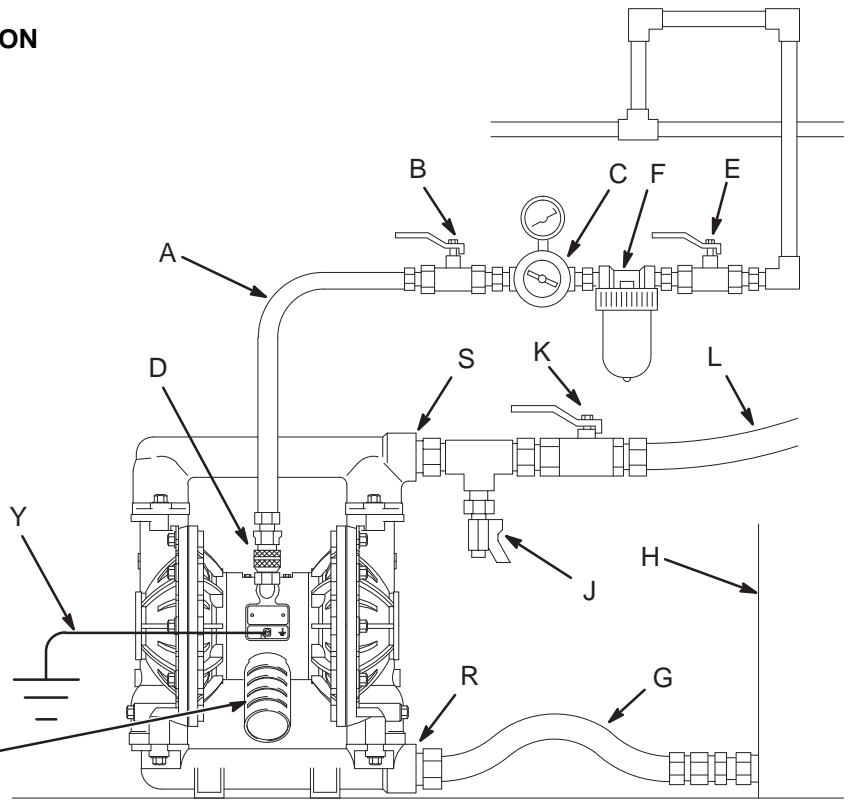

03265B

FIG. 2

# Installation

## Changing the Orientation of the Fluid Inlet and Outlet Ports

**NOTE:** Remove and rotate the center manifold(s) to change the orientation of inlet or outlet port(s). Follow the **Torque Instructions**, page 31.

### KEY

▲ Apply medium-strength (blue) thread locker to the threads. See **Torque Instructions**, page 31.

▲ Apply medium-strength (blue) thread locker to the threads. See **Torque Instructions**, page 31.

N	1/2 in. npt(f) air inlet port	101	Covers
P	Muffler. (Not included on Model No. 253485)	102	Fluid inlet manifold
		103	Fluid outlet manifold
		106	Manifold and cover screws
		112	Bottom cover screws

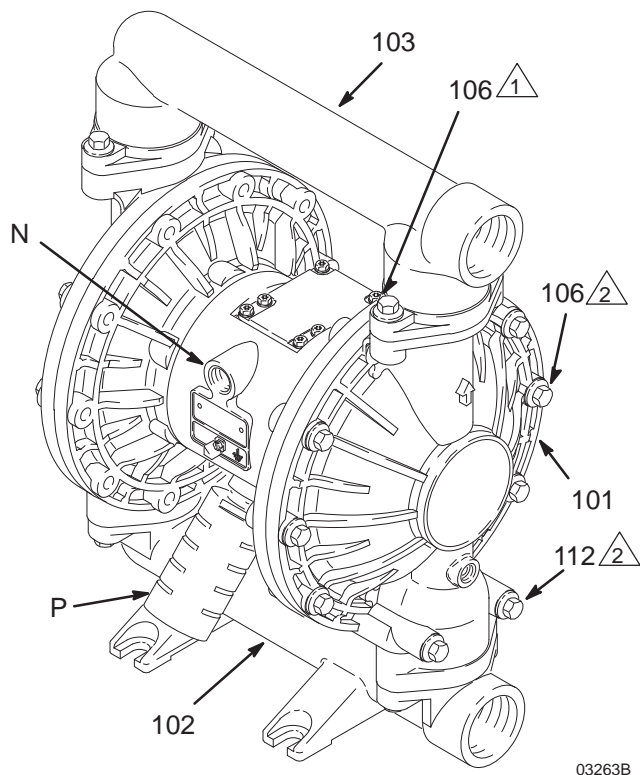

Aluminum Model Shown

FIG. 3

## Fluid Pressure Relief Valve

### ▲ CAUTION

Some systems may require installation of a pressure relief valve at the pump outlet to prevent overpressurization and rupture of the pump or hose. See FIG. 4.

Thermal expansion of fluid in the outlet line can cause overpressurization. This can occur when using long fluid lines exposed to sunlight or ambient heat, or when pumping from a cool to a warm area (for example, from an underground tank).

Overpressurization can also occur if the Husky pump is being used to feed fluid to a piston pump, and the intake valve of the piston pump does not close, causing fluid to back up in the outlet line.

### KEY

R	1.5 in. npt(f) fluid inlet port
S	1.5 in. npt(f) fluid outlet port
V	Pressure relief valve (Order Part No. 112119 for stainless steel pumps)

▲1 Install valve between fluid inlet and outlet ports.

▲2 Connect fluid inlet line here.

▲3 Connect fluid outlet line here.

▲4 Muffler not included on Model No. 253485

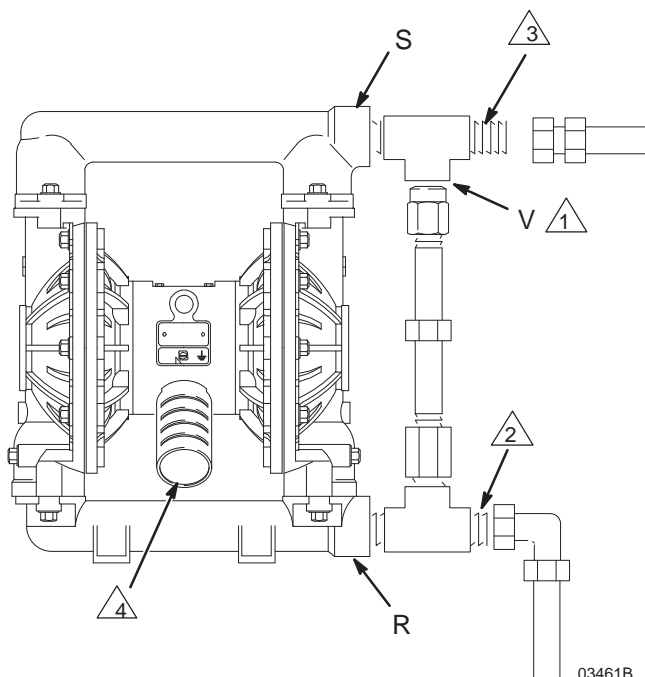

FIG. 4

# Installation

## Air Exhaust Ventilation

### **⚠ WARNING**



#### **FIRE AND EXPLOSION HAZARD**

Be sure to read and follow the warnings and precautions regarding **TOXIC FLUID HAZARD**, and **FIRE AND EXPLOSION HAZARD** on page 5, before operating this pump.

Be sure the system is properly ventilated for your type of installation. You must vent the exhaust to a safe place, away from people, animals, food handling areas, and all sources of ignition when pumping flammable or hazardous fluids.

Diaphragm failure will cause the fluid being pumped to exhaust with the air. Place an appropriate container at the end of the air exhaust line to catch the fluid. See FIG. 5.

The air exhaust port is 3/4 npt(f). Do not restrict the air exhaust port. Excessive exhaust restriction can cause erratic pump operation.

If the muffler (P) is installed directly to the air exhaust port, apply PTFE thread tape or anti-seize thread lubricant to the muffler threads before assembly.

To provide a remote exhaust:

1. Remove the muffler (P) from the pump air exhaust port.
2. Install a grounded air exhaust hose (T) and connect the muffler (P) to the other end of the hose. The minimum size for the air exhaust hose is 3/4 in. (19 mm) ID. If a hose longer than 15 ft (4.57 m) is required, use a larger diameter hose. Avoid sharp bends or kinks in the hose. See FIG. 4.
3. Place a container (U) at the end of the air exhaust line to catch fluid in case a diaphragm ruptures.

### VENTING EXHAUST AIR

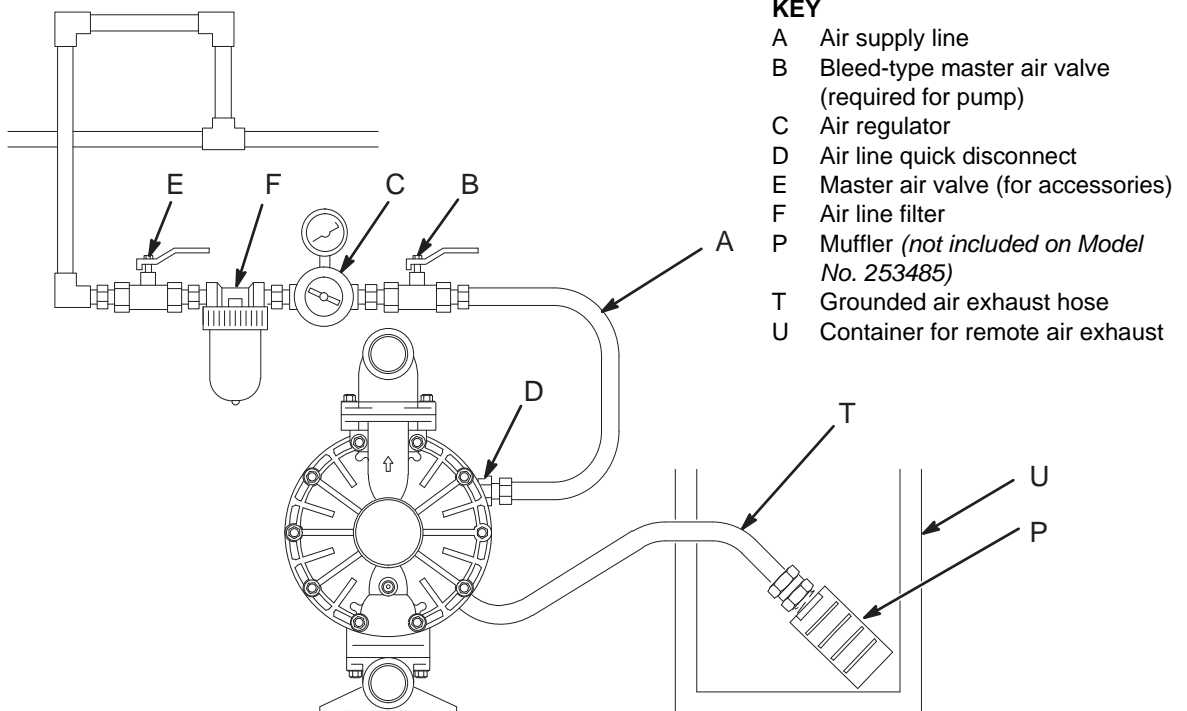

Fig. 5

03267A

# Operation

## Pressure Relief Procedure

### **WARNING**

#### **PRESSURIZED EQUIPMENT HAZARD**

The equipment stays pressurized until pressure is manually relieved. To reduce the risk of serious injury from pressurized fluid, accidental spray from the gun or splashing fluid, follow this procedure whenever you:

- Are instructed to relieve pressure,
- Stop pumping,
- Check, clean or service any system equipment,
- Install or clean fluid nozzles.

1. Shut off the air to the pump.
2. Open the dispensing valve, if used.
3. Open the fluid drain valve to relieve all fluid pressure, having a container ready to catch the drainage.

## Flush the Pump Before First Use

The pump was tested in water. If water could contaminate the fluid you are pumping, flush the pump thoroughly with a compatible solvent. Follow the steps under **Starting and Adjusting the Pump**.

## Starting and Adjusting the Pump

### **WARNING**

#### **TOXIC FLUID HAZARD**

To reduce the risk of serious injury, splashing in the eyes or on the skin, and toxic fluid spills, **never** move or lift a pump under pressure. If dropped, the fluid section may rupture. Always follow the **Pressure Relief Procedure** above before lifting the pump.

1. Be sure the pump is properly grounded. Refer to **Installation** on page 7.
2. Check all fittings to be sure they are tight. Be sure to use a compatible liquid thread sealant on all male threads. Tighten the fluid inlet and outlet fittings securely.
3. Place the suction tube (if used) in the fluid to be pumped.

**NOTE:** If the fluid inlet pressure to the pump is more than 25% of the outlet working pressure, the ball check valves will not close fast enough, resulting in inefficient pump operation.

4. Place the end of the fluid hose (L) into an appropriate container.
5. Close the fluid drain valve (J). See FIG. 2.
6. Close the pump air regulator (C). Open all bleed-type master air valves (B, E).
7. If the fluid hose has a dispensing device, hold it open while continuing with the following step.
8. Slowly open the air regulator (C) until the pump starts to cycle. Allow the pump to cycle slowly until all air is pushed out of the lines and the pump is primed.

*If you are flushing, run the pump long enough to thoroughly clean the pump and hoses. Close the air regulator. Remove the suction tube from the solvent and place it in the fluid to be pumped.*

## Operation of Remote Piloted Pumps

1. Follow preceding steps 1 through 7 of **Starting and Adjusting the Pump**.
2. Open air regulator (C).

### **WARNING**

The pump may cycle once before the external signal is applied. Injury is possible. If pump cycles, wait until end before proceeding.

3. Pump will operate when air pressure is alternately applied and relieved to push type connectors (14).

**NOTE:** Leaving air pressure applied to the air motor for extended periods when the pump is not running may shorten the diaphragm life. Using a 3-way solenoid valve to automatically relieve the pressure on the air motor when the metering cycle is complete prevents this from occurring.

## Pump Shutdown

### **WARNING**

To reduce the risk of serious injury whenever you are instructed to relieve pressure, always follow the **Pressure Relief Procedure** at left.

At the end of the work shift, relieve the pressure.

# Maintenance

## Lubrication

The air valve is designed to operate unlubricated, however if lubrication is desired, every 500 hours of operation (or monthly) remove the hose from the pump air inlet and add two drops of machine oil to the air inlet.

### CAUTION

Do not over-lubricate the pump. Oil is exhausted through the muffler, which could contaminate your fluid supply or other equipment. Excessive lubrication can also cause the pump to malfunction.

## Tightening Threaded Connections

Before each use, check all hoses for wear or damage, and replace as necessary. Check to be sure all threaded connections are tight and leak-free.

Check fasteners. Tighten or retorque as necessary. Although pump use varies, a general guideline is to retorque fasteners every two months. See **Torque Instructions**, page 31.

## Flushing and Storage

### WARNING

To reduce the risk of serious injury whenever you are instructed to relieve pressure, always follow the **Pressure Relief Procedure** on page 12.

Flush the pump often enough to prevent the fluid you are pumping from drying or freezing in the pump and damaging it. Use a compatible solvent.

Always flush the pump and relieve the pressure before storing it for any length of time.

# Troubleshooting

## WARNING

To reduce the risk of serious injury whenever you are instructed to relieve pressure, always follow the **Pressure Relief Procedure** on page 12.

- Relieve the pressure before checking or servicing the equipment.
- Check all possible problems and causes before disassembling the pump.

PROBLEM	CAUSE	SOLUTION
Pump cycles at stall or fails to hold pressure at stall.	Worn check valve balls (301), seats (201) or o-rings (202).	Replace. See page 18.
Pump will not cycle, or cycles once and stops.	Air valve is stuck or dirty.	Disassemble and clean air valve. See pages 16-17. Use filtered air.
	Check valve ball (301) severely worn and wedged in seat (201) or manifold (102 or 103).	Replace ball and seat. See page 18.
	Check valve ball (301) is wedged into seat (201), due to overpressurization.	Install Pressure Relief Valve (see page 10).
	Dispensing valve clogged.	Relieve pressure and clear valve.
Pump operates erratically.	Clogged suction line.	Inspect; clear.
	Sticky or leaking balls (301).	Clean or replace. See page 18.
	Diaphragm ruptured.	Replace. See pages 19-21.
	Restricted exhaust.	Remove restriction.
Air bubbles in fluid.	Suction line is loose	Tighten.
	Diaphragm ruptured.	Replace. See pages 19-21.
	Loose inlet manifold (102), damaged seal between manifold and seat (201), damaged o-rings (202).	Tighten manifold bolts (106) or replace seats (201) or o-rings (202). See page 18.
	Loose diaphragm shaft bolt (107).	Tighten or replace. See pages 19-21.
	Damaged o-ring (108).	Replace. See pages 19-21.

# Troubleshooting

PROBLEM	CAUSE	SOLUTION
Fluid in exhaust air.	Diaphragm ruptured.	Replace. See pages 19-21.
	Loose diaphragm shaft bolt (107).	Tighten or replace. See pages 19-21.
	Damaged o-ring (108).	Replace. See pages 19-21.
Pump exhausts excessive air at stall.	Worn air valve block (7), o-ring (6), plate (8), pilot block (18), u-cups (10), or pilot pin o-rings (17).	Repair or replace. See pages 16-17.
	Worn shaft seals (402).	Replace. See pages 19-21.
Pump leaks air externally.	Air valve cover (2) or air valve cover screws (3) are loose.	Tighten screws. See page 17.
	Air valve gasket (4) or air cover gasket (22) is damaged.	Inspect; replace. See pages 16-17, 22-23.
	Air cover screws (25) are loose.	Tighten screws. See pages 22-23.
Pump leaks fluid externally from ball check valves.	Loose manifolds (102, 103), damaged seal between manifold and seat (201), damaged o-rings (202).	Tighten manifold bolts (106) or replace seats (201) or o-rings (202). See page 18.

# Service

## Repairing the Air Valve

### Tools Required

- Torque wrench
- Torx (T20) screwdriver or 7 mm (9/32 in.) socket wrench
- Needle-nose pliers
- O-ring pick
- Lithium base grease

**NOTE:** Air Valve Repair Kits 236273 (aluminum center housing models) and 255061 (sst center housing models) are available. Refer to page 28. Parts included in the kit are marked with a symbol, for example (4†■). Use all the parts in the kit for the best results.

### Disassembly

#### **WARNING**

To reduce the risk of serious injury whenever you are instructed to relieve pressure, always follow the **Pressure Relief Procedure** on page 12.

1. Relieve the pressure.
2. With a Torx (T20) screwdriver or 7 mm (9/32 in.) socket wrench, remove the six screws (3), air valve cover (2), and gasket (4). See FIG. 6.
3. Move the valve carriage (5) to the center position and pull it out of the cavity. Remove the valve block (7†■) and o-ring (6†■) from the carriage. Using a needle-nose pliers, pull the pilot block (18) straight up and out of the cavity. See FIG. 7.
4. Pull the two actuator pistons (11) out of the bearings (12). Remove the u-cup packings (10) from the pistons. Pull the pilot pins (16) out of the bearings (15). Remove the o-rings (17) from the pilot pins. See FIG. 8.
5. Inspect the valve plate (8■) in place. If damaged, use a Torx (T20) screwdriver or 7 mm (9/32 in.) socket wrench to remove the three screws (3). Remove the valve plate (8■) and, on aluminum center housing models only, remove the seal (9). See FIG. 9.
6. Inspect the bearings (12, 15) in place. See FIG. 8. The bearings are tapered and, if damaged, must be removed from the outside. This requires disassembly of the fluid section. See page 22.
7. Clean all parts and inspect for wear or damage. Replace as needed. Reassemble as explained on page 17.

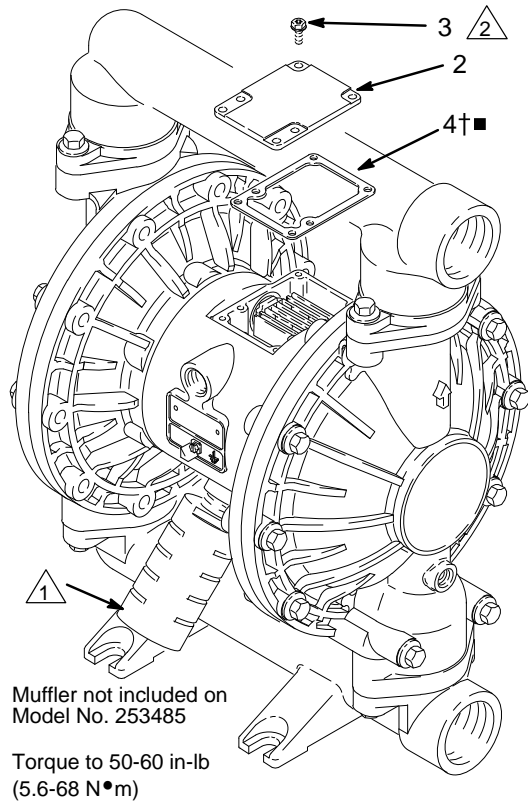

FIG. 6

03268B

- 1 See Detail at right.
- 2 Grease.
- 3 Grease lower face.

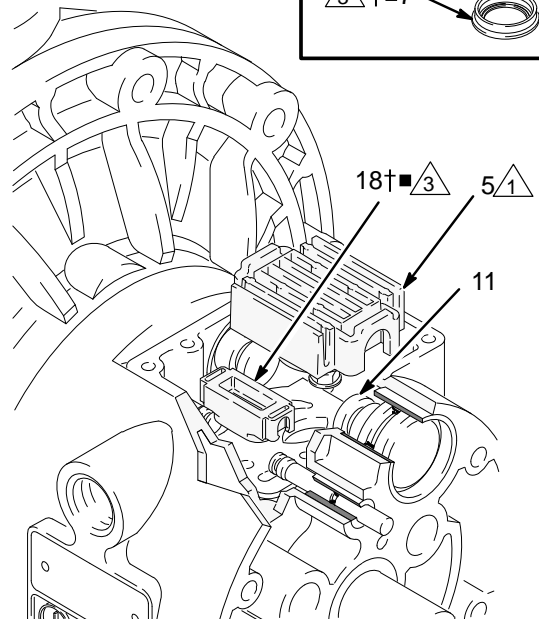
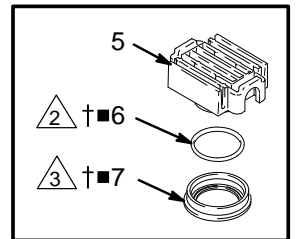

FIG. 7

03269



# Service

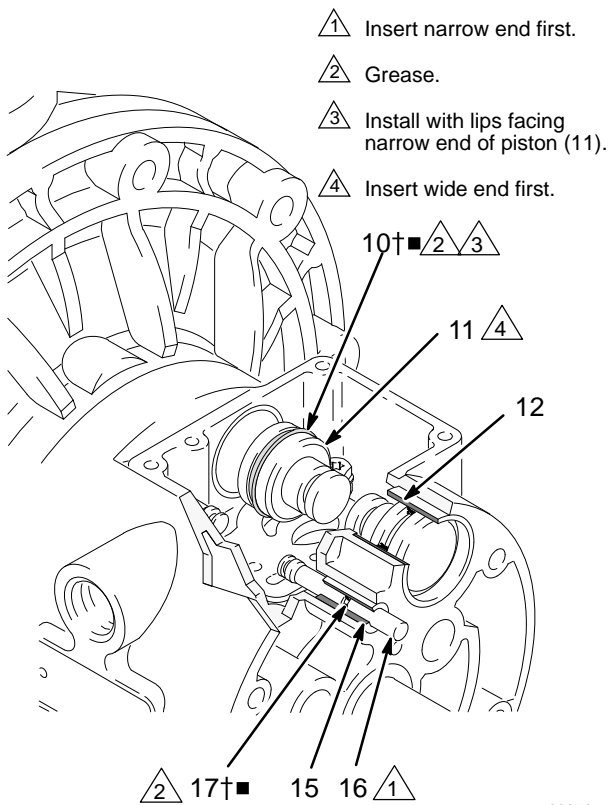

FIG. 8

03270

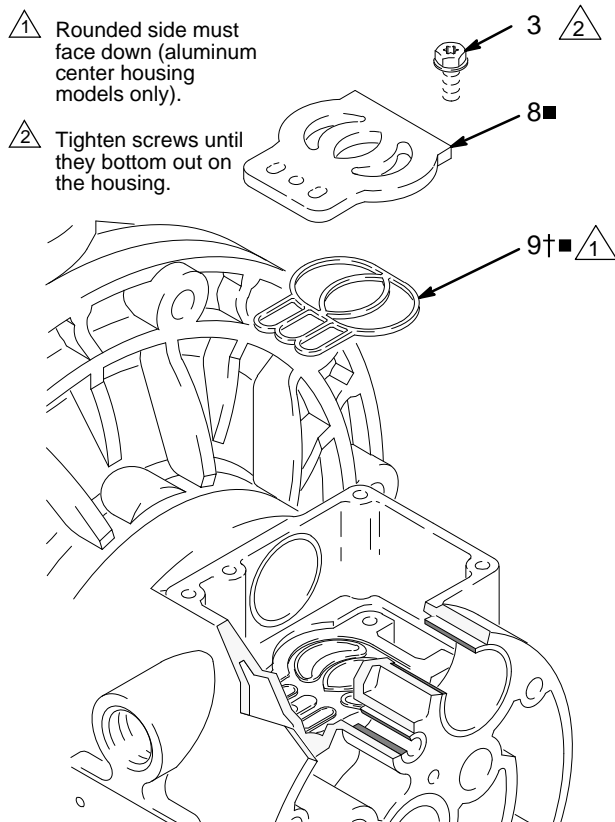

FIG. 9

03271

## Reassembly

1. If you removed the bearings (12, 15), install new ones as explained on page 22. Reassemble the fluid section.
2. On aluminum center housing models, install the valve plate seal (9) into the groove at the bottom of the valve cavity. The rounded side of the seal **must face down** into the groove. See FIG. 9.
3. Install the valve plate (8) in the cavity. On aluminum center housing models, the plate is reversible, so either side can face up. Install the three screws (3), using a Torx (T20) screwdriver or 7 mm (9/32 in.) socket wrench. Tighten until the screws bottom out on the housing. See FIG. 9.
4. Install an o-ring (17) on each pilot pin (16). Grease the pins and o-rings. Insert the pins into the bearings (15), **narrow** end first. See FIG. 8.
5. Install a u-cup packing (10) on each actuator piston (11), so the lips of the packings face the **narrow** end of the pistons. See FIG. 8.
6. Lubricate the u-cup packings (10) and actuator pistons (11). Insert the actuator pistons in the bearings (12), **wide** end first. Leave the narrow end of the pistons exposed. See FIG. 8.
7. Grease the lower face of the pilot block (18) and install so its tabs snap into the grooves on the ends of the pilot pins (16). See FIG. 7.
8. Grease the o-ring (6) and install it in the valve block (7). Push the block onto the valve carriage (5). Grease the lower face of the valve block. See FIG. 7.
9. Install the valve carriage (5) so its tabs slip into the grooves on the narrow end of the actuator pistons (11). See FIG. 7.
10. Align the valve gasket (4) and cover (2) with the six holes in the center housing (1). Secure with six screws (3), using a Torx (T20) screwdriver or 7 mm (9/32 in.) socket wrench. Torque to 50-60 in-lb (5.6-6.8 N•m). See FIG. 6.

# Service

## Ball Check Valve Repair

### Tools Required

- Torque wrench
- 13 mm socket wrench
- O-ring pick

### Disassembly

**NOTE:** A Fluid Section Repair Kit is available. Refer to page 26 to order the correct kit for your pump. Parts included in the kit are marked with an asterisk, for example (201\*). Use all the parts in the kit for the best results.

**NOTE:** To ensure proper seating of the balls (301), always replace the seats (201) when replacing the balls. Also, on some models, replace the o-rings (202).

### **⚠ WARNING**

To reduce the risk of serious injury whenever you are instructed to relieve pressure, always follow the **Pressure Relief Procedure** on page 12.

1. Relieve the pressure. Disconnect all hoses.
2. Remove the pump from its mounting.
3. Using a 13 mm socket wrench, remove the four bolts (106) holding the outlet manifold (103) to the fluid covers (101). See FIG. 10.
4. Remove the o-rings (202, *not used on some models*), seats (201), and balls (301) from the manifold.
5. Turn the pump over and remove the inlet manifold (102). Remove the o-rings (202, *not used on some models*), seats (201), and balls (301) from the fluid covers (101).

### Reassembly

1. Clean all parts and inspect for wear or damage. Replace parts as needed.
2. Reassemble in the reverse order, following all notes in FIG. 10. Be sure the ball checks are assembled **exactly** as shown. The arrows (A) on the fluid covers (101) **must** point toward the outlet manifold (103).

1. Apply medium-strength (blue) thread locker to the threads. Torque to 120-150 in-lb (14-17 N•m). See **Torque Instructions**, page 31.
2. Arrow (A) must point toward outlet manifold (103).
3. Not used on some models.
4. Beveled seating surface must face ball (301).

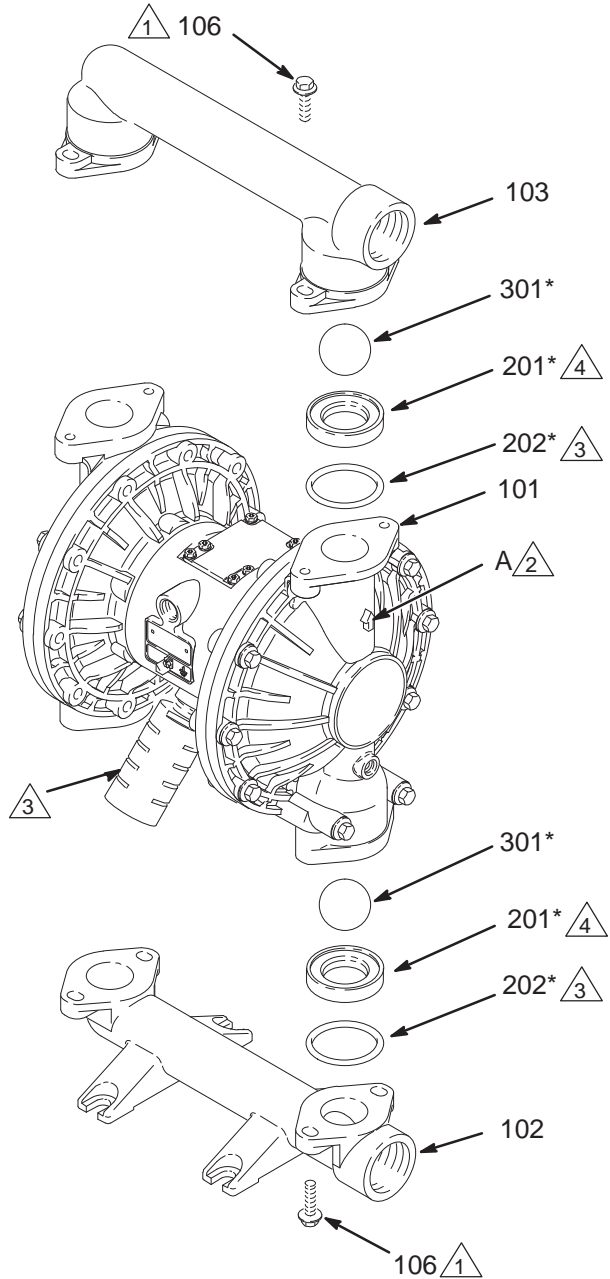

FIG. 10

03272B

# Service

## Diaphragm Repair

### Tools Required

- Torque wrench
- 13 mm socket wrench
- 15 mm socket wrench (aluminum models) or 1 in. socket wrench (stainless steel models)
- 19 mm open-end wrench
- O-ring pick
- Lithium-base grease

### Disassembly

**NOTE:** A Fluid Section Repair Kit is available. Refer to page 23 to order the correct kit for your pump. Parts included in the kit are marked with an asterisk, for example (401\*). Use all the parts in the kit for the best results.

## WARNING

To reduce the risk of serious injury whenever you are instructed to relieve pressure, always follow the **Pressure Relief Procedure** on page 12.

1. Relieve the pressure.
2. Remove the manifolds and disassemble the ball check valves as explained on page 18.
3. Using a 13 mm socket wrench, remove the screws (106 and 112) holding the fluid covers (101) to the air covers (23). Pull the fluid covers (101) off the pump. See FIG. 11.

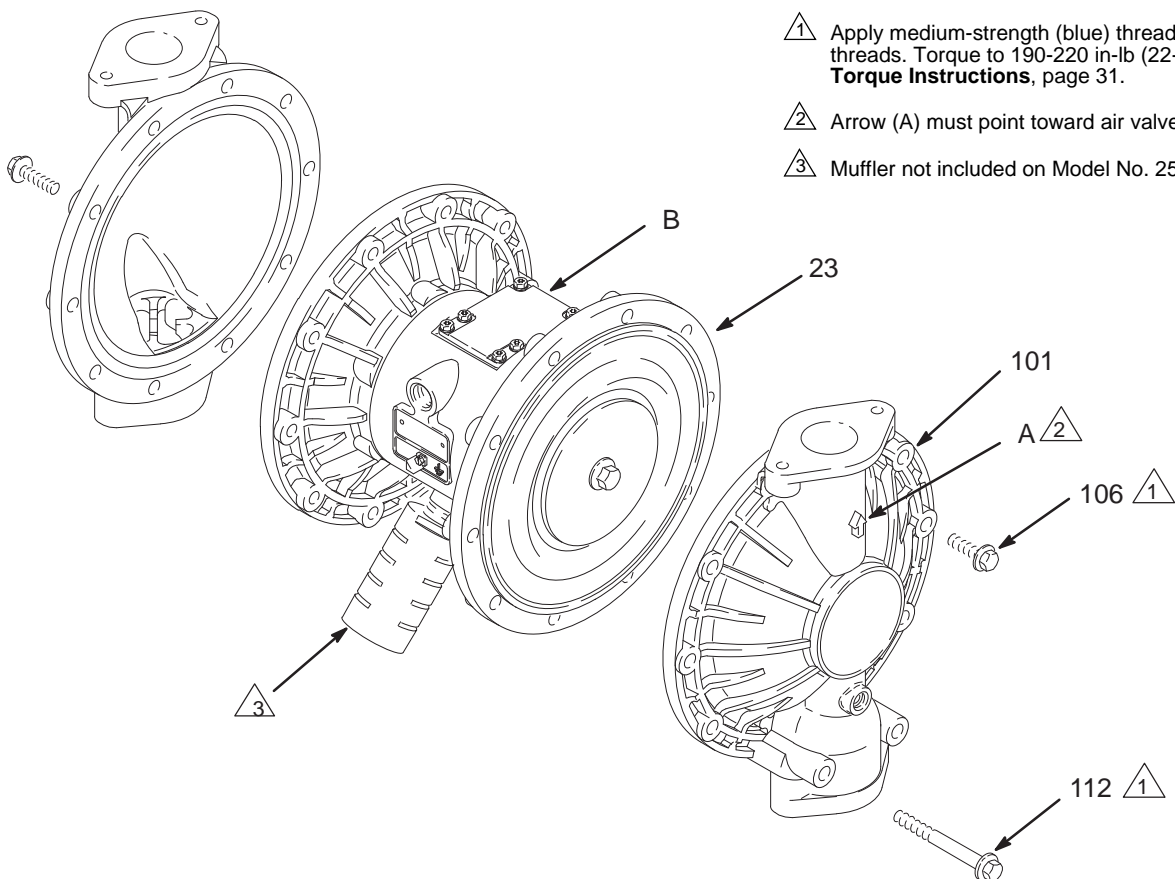

FIG. 11

03273C

# Service

4. Loosen but do not remove the diaphragm shaft bolts (107), using a 15 mm socket wrench (1 in. on stainless steel models) on both bolts. *NOTE: This step does not apply to pumps with overmolded diaphragms.*
5. Unscrew one bolt from the diaphragm shaft (24) and remove the o-ring (108), fluid side diaphragm plate (105), PTFE diaphragm (403, *used on PTFE models only*), diaphragm (401), and air side diaphragm plate (104). See FIG. 12.

*For overmolded diaphragms:* Grip both diaphragms securely around the outer edge and rotate counterclockwise. One diaphragm assembly will come free and the other will remain attached to the shaft. Remove the freed diaphragm and air side plate.

6. Pull the other diaphragm assembly and the diaphragm shaft (24) out of the center housing (1). Hold the shaft flats with a 19 mm open-end wrench, and remove the bolt (107) from the shaft. Disassemble the remaining diaphragm assembly.

*For overmolded diaphragms:* Pull the other diaphragm assembly and the diaphragm shaft (24) out of the center housing (1). Hold the shaft flats with a 19 mm open-end wrench and remove the diaphragm and air side plate from the shaft.

7. Inspect the diaphragm shaft (24) for wear or scratches. If it is damaged, inspect the bearings (19) in place. If the bearings are damaged, refer to page 22.
8. Reach into the center housing (1) with an o-ring pick and hook the u-cup packings (402), then pull them out of the housing. This can be done with the bearings (19) in place.
9. Clean all parts and inspect for wear or damage. Replace parts as needed.

## Reassembly

1. Install the shaft u-cup packings (402\*) so the lips face **out** of the housing (1). Lubricate the packings. See FIG. 12.
2. Install the diaphragm assembly on one end of the shaft (24) as follows. *For pumps with overmolded diaphragms, go directly to step g.*

- a. Install the o-ring (108\*) on the shaft bolt (107).
- b. Install the fluid side diaphragm plate (105) on the bolt so the rounded side faces in, toward the diaphragm (401).
- c. *On PTFE models only*, install the PTFE diaphragm (403\*). Make certain the side marked AIR SIDE faces the center housing (1).
- d. Install the diaphragm (401\*) on the bolt. Make certain the side marked AIR SIDE faces the center housing (1).
- e. Install the air side diaphragm plate (104) so the recessed side faces the diaphragm (401).
- f. Apply medium-strength (blue) thread locker to the bolt (107) threads. Screw the bolt (107) into the shaft (24) hand tight.
- g. *For overmolded diaphragms:* Assemble the air side plate (104) onto the diaphragm (403). The wide, radiused side of the plate must face the diaphragm. Apply medium-strength (blue) thread locker to the threads of the diaphragm assembly. Screw the assembly into the shaft (24) hand tight.

3. Grease the length and ends of the diaphragm shaft (24), and slide it through the housing (1).
4. Assemble the other diaphragm assembly to the shaft as explained in step 2.
5. Hold one shaft bolt (107) with a wrench and torque the other bolt to 20-25 ft-lb (27-34 N•m) at 100 rpm maximum. *NOTE: This step does not apply to pumps with overmolded diaphragms.*
6. Align the fluid covers (101) and the center housing (1) so the arrows (A) on the covers face the same direction as the air valve (B). Apply medium-strength (blue) thread locker to the threads of screws (106) and (112), and secure the covers with the screws handtight. Install the longer screws (112) in the bottom holes of the covers. See Fig. 11. Using a 13 mm socket wrench, torque the screws oppositely and evenly to 190-220 in-lb (22-25 N•m). See **Torque Instructions**, page 31.
7. Reassemble the ball check valves and manifolds as explained on page 18.

# Service

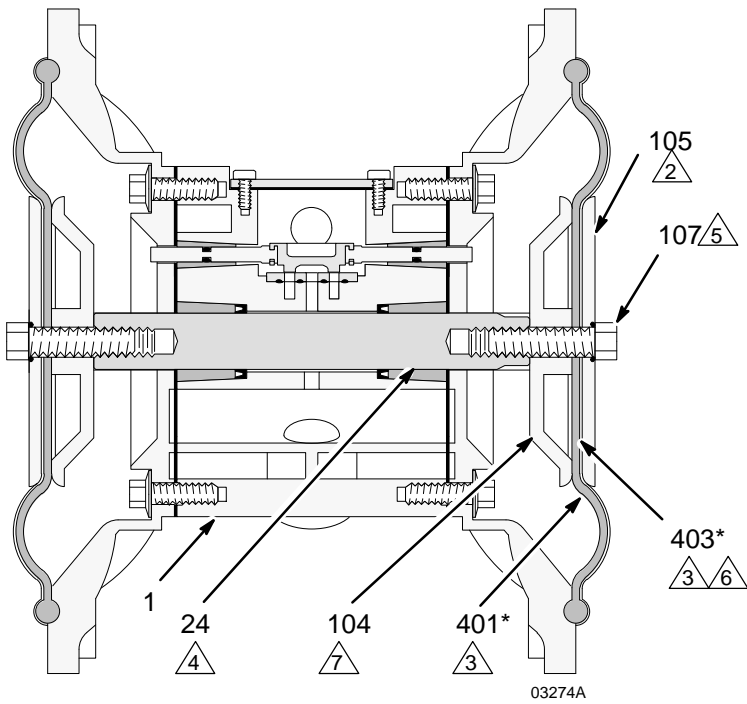

**Cutaway View, with Diaphragms in Place**

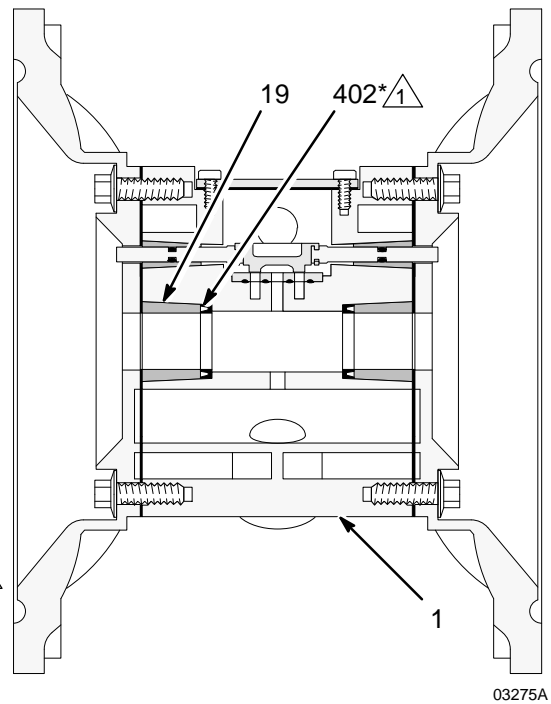

**Cutaway View, with Diaphragms Removed**

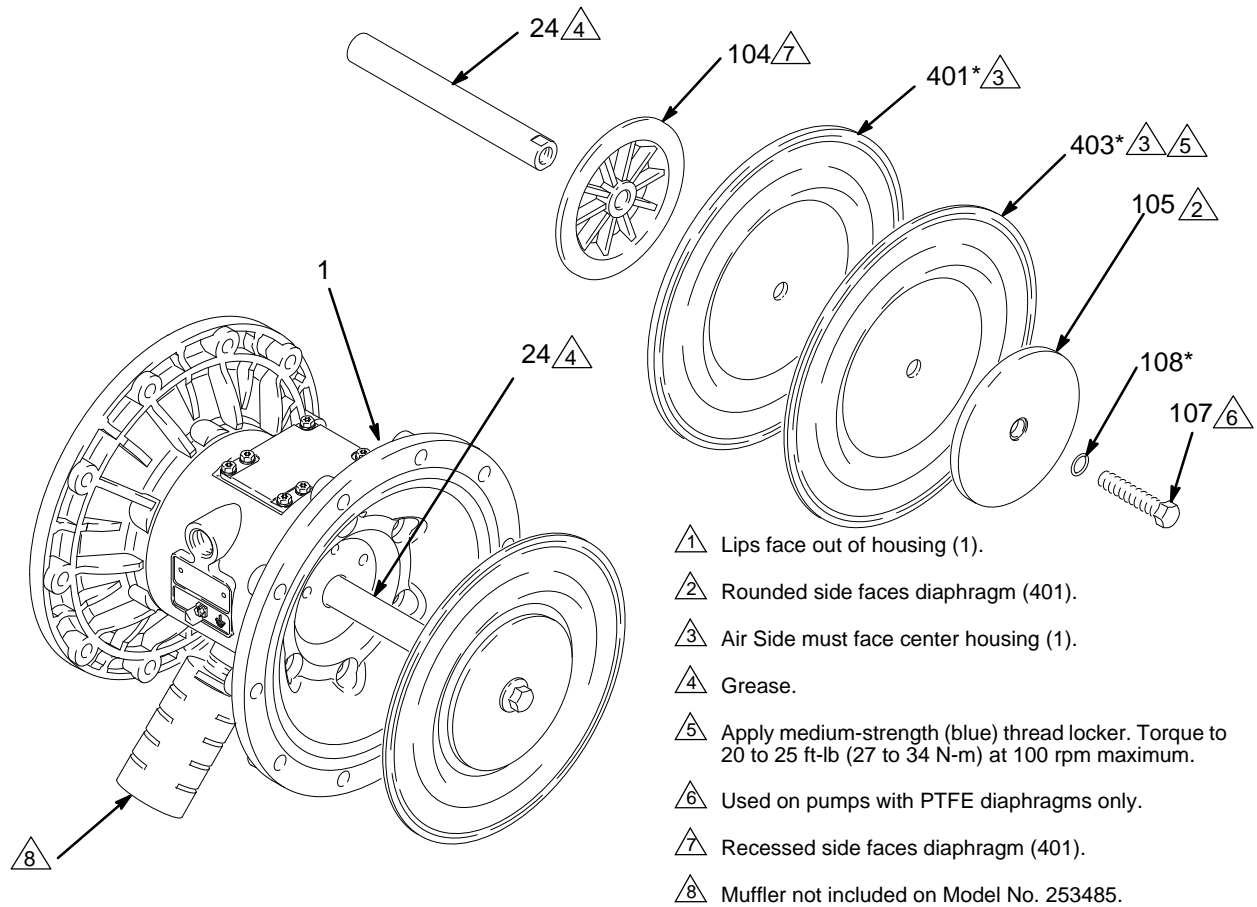

**FIG. 12**

03276C

# Service

## Bearing and Air Gasket Removal

### Tools Required

- Torque wrench
- 10 mm socket wrench
- Bearing puller
- O-ring pick
- Press, or block and mallet

### Disassembly

**NOTE:** Do not remove undamaged bearings.

### WARNING

To reduce the risk of serious injury whenever you are instructed to relieve pressure, always follow the **Pressure Relief Procedure** on page 12.

1. Relieve the pressure.
  2. Remove the manifolds and disassemble the ball check valves as explained on page 18.
  3. Remove the fluid covers and diaphragm assemblies as explained on page 19.
- NOTE:** If you are removing only the diaphragm shaft bearing (19), skip step 4.
4. Disassemble the air valve as explained on page 16.
  5. Using a 10 mm socket wrench, remove the screws (25) holding the air covers (23) to the center housing (1). See FIG. 13.
  6. Remove the air cover gaskets (22). Always replace the gaskets with new ones.
  7. Use a bearing puller to remove the diaphragm shaft bearings (19), air valve bearings (12) or pilot pin bearings (15). Do not remove undamaged bearings.
  8. If you removed the diaphragm shaft bearings (19), reach into the center housing (1) with an o-ring pick

and hook the u-cup packings (402), then pull them out of the housing. Inspect the packings. See FIG. 12.

### Reassembly

1. If removed, install the shaft u-cup packings (402\*) so the lips face **out** of the housing (1).
2. The bearings (12, 15, and 19) are tapered and can only be installed one way. Insert the bearings into the center housing (1), **tapered end first**. Using a press or a block and rubber mallet, press-fit the bearing so it is flush with the surface of the center housing.
3. Reassemble the air valve as explained on page 17.
4. Align the new air cover gasket (22) so the pilot pin (16) protruding from the center housing (1) fits through the proper hole (H) in the gasket.
5. Align the air cover (23) so the pilot pin (16) fits in the middle hole (M) of the three small holes near the center of the cover. Apply medium-strength (blue) thread locker to the threads of screws (25), and install the screws handtight. See FIG. 13. Using a 10 mm socket wrench, torque the screws oppositely and evenly to 130-150 in-lb (15-17 N•m).
6. Install the diaphragm assemblies and fluid covers as explained on page 19.
7. Reassemble the ball check valves and manifolds as explained on page 18.

# Service

- 1 Insert bearings tapered end first.
- 2 Press-fit bearings flush with surface of center housing (1).
- 3 Apply medium-strength (blue) thread locker. Torque to 130-150 in-lb (15-17 N•m).
- 4 Muffler not included on Model No. 253485.

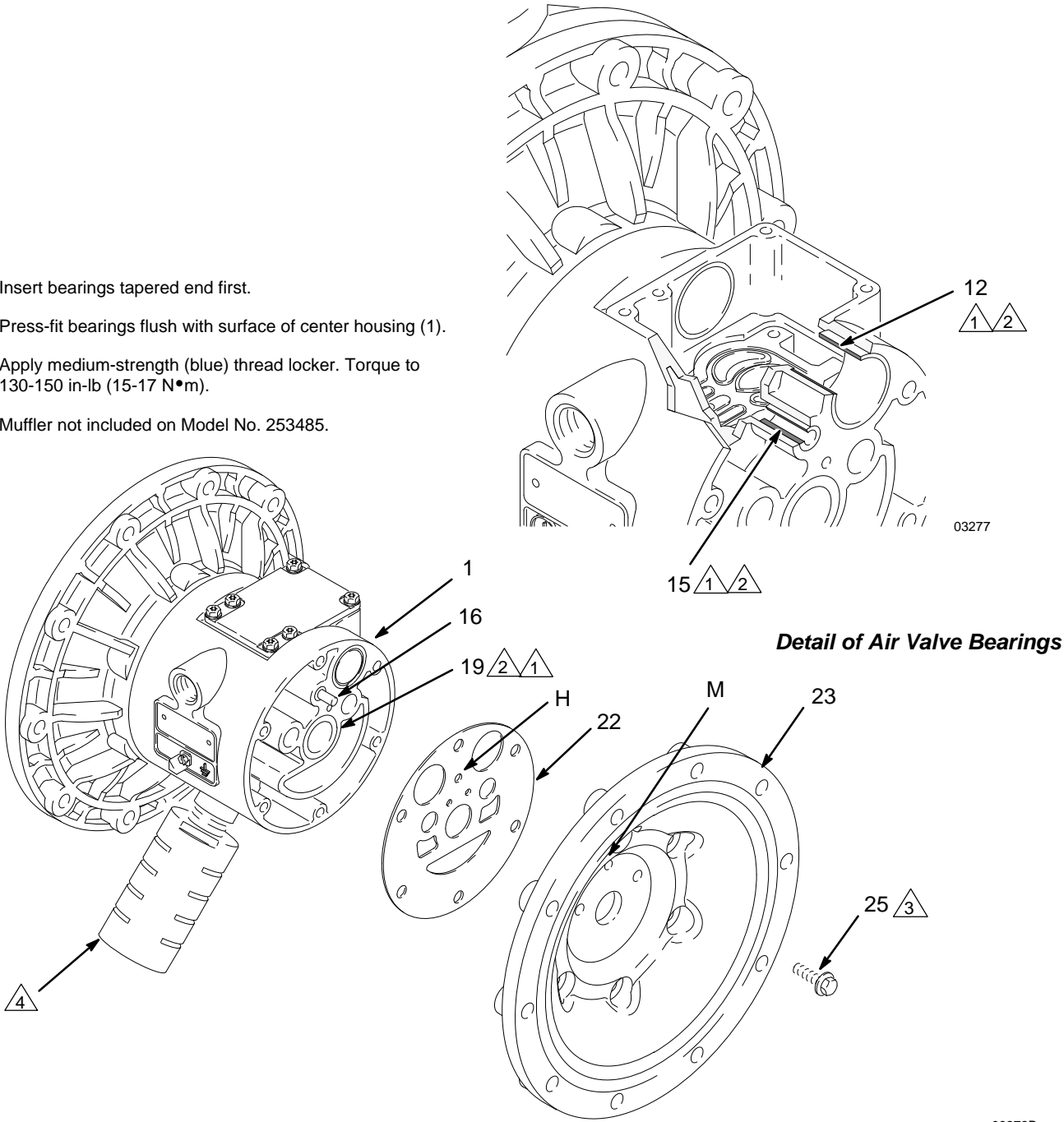

FIG. 13

# Pump Matrix

## Husky 1590 Aluminum and Stainless Steel Pumps, Series A

Your Model No. is marked on the pump's serial plate. To determine the Model No. of your pump from the following matrix, select the six digits which describe your pump, working from left to right. The first digit is always **D**, designating Husky diaphragm pumps. The remaining five digits define the materials of construction. For example, a pump with an aluminum air motor, aluminum fluid section, polypropylene seats, PTFE balls, and PTFE diaphragms is Model No.

**D B 3 9 1 1.** To order replacement parts, refer to the part lists on pages 27-28. *The digits in the matrix do not correspond to the ref. nos. in the parts drawing and lists.*

Diaphragm pump	Air Motor	Fluid Section	–	Seats	Balls	Diaphragms
232502*	aluminum	aluminum	–	TPE	acetal	acetal
253485*	aluminum	aluminum	–	Buna-N	Buna-N	Buna-N
25C654	sst	sst	–	sst	PTFE	PTFE/EPDM Overmolded
25C655	aluminum	sst	–	sst	PTFE	PTFE/EPDM Overmolded
25C656	sst	sst	–	sst	PTFE	PTFE/EPDM Overmolded
25C657	aluminum	sst	–	sst	PTFE	PTFE/EPDM Overmolded
D (for all pumps)	B aluminum (standard)	1 (not used)	–	1 (not used)	1 (PTFE)	1 (PTFE)
		2 (not used)	–	2 (not used)	2 (acetal)	2 (not used)
24B780*	C aluminum (remote)	3 (aluminum)	–	3 (316 sst)	3 (not used)	3 (not used)
		4 (sst)	–	4 (17-4 PH sst)	4 (440C sst)	4 (not used)
24B781*	T sst (standard)	5 (not used)	–	5 (TPE)	5 (TPE)	5 (TPE)
		7 (sst 3.1 Cert.)	–	6 (Santoprene®)	6 (Santoprene®)	6 (Santoprene®)
24G411*	U sst (remote)	8 (sst 3.1 Adv. Cert.)	–	7 (Buna-N)	7 (Buna-N)	7 (Buna-N)
			–	8 (Fluoroelastomer)	8 (Fluoroelastomer)	8 (Fluoroelastomer)
		C (aluminum BSPT)	–	9 (polypropylene)	9 (not used)	9 (not used)
			–	A (PVDF)	A (not used)	A (not used)
		D (sst BSPT)	–	G (Geolast®)	G (Geolast®)	G (Geolast®)
		P (sst vertical center flange)				
		R (sst horiz. center flange)				



**246451 Stainless Steel Air Motor Conversion Kit**

Use kit 246451 and refer to manual 309643 (included with kit) to convert from aluminum air motor to stainless steel air motor.

**\* 232502, Aluminum 1590 Pump, Series D**

Model No. 232502 is a private-label aluminum 1590 pump. This pump is the same as Model No. DB3525 except for the label and:

Ref. Nos. 10 and 402 are 115666 Packing, U-cup, Fluoroelastomer

Ref. No. 17 is 168518 O-ring, Fluoroelastomer

Use 243492 as the Air Valve Repair Kit

Ref. 106 is 112416 SCREW, SST; M10 x 1.5, 30 mm

Ref. 112 is 112417 SCREW, SST; M10 x 1.5; 90 mm

**\* 253485, Aluminum 1590 Pump, Series A**

Model No. 253485 is an aluminum 1590 pump. This pump is the same as Model No. DB3777 except for the label and that 253485 does not include Ref. No. 111 Muffler.

**\* 24B780 Stainless Steel Plus Pump**

This pump is the same as Model DT4311 except for the serial plate and parts listed in the chart below.

**\* 24B781 Stainless Steel Pump**

This pump is the same as Model DB4311 except for the serial plate and parts listed in the chart below.

**\* 24G411 Aluminum Pump**

This pump is the same as Model DBC311 except for the serial plate and parts listed in the chart below.

**\* 24J358 Aluminum Pump**

This pump is the same as Model DB3311 except for the serial plate and parts listed in the chart below.

**\* 24J359 Aluminum Pump**

This pump is the same as Model DB3321 except for the serial plate and parts listed in the chart below.

**\* 25A017 Aluminum Pump**

This pump is the same as Model DB3341 except for the serial plate and parts listed in the chart below.

**\* 25C654 Stainless Steel Pump**

This pump is the same as Model DTR315 except for the serial plate and parts listed in the chart below.

**\* 25C655 Stainless Steel Pump**

This pump is the same as Model DBR315 except for the serial plate and parts listed in the chart below.

**\* 25C656 Stainless Steel Pump**

This pump is the same as Model DTP315 except for the serial plate and parts listed in the chart below.

**\* 25C657 Stainless Steel Pump**

This pump is the same as Model DBP315 except for the serial plate and parts listed in the chart below.

Ref. No.	Part No.	Description	Qty.
104	15H810	PLATE, air side; alum.	2
105	—	not used	0
107	—	not used	0
108	—	not used	0
401	253627	DIAPHRAGM, HD, overmolded; PTFE/EPDM	2

# Repair Kit Matrix

## For Husky 1590 Aluminum and Stainless Steel Pumps, Series A

Repair Kits may be ordered separately. To repair the air valve, order **Part No. 236273** for aluminum center housing models or **Part No. 255061** for stainless steel center housing models (see page 29). Parts included in the Air Valve Repair Kit are marked with a symbol in the parts list, for example (3).

To repair your pump, select the six digits which describe your pump from the following matrix, working from left to right. The first digit is always **D**, the second digit is always **0** (zero), and the third is always **B**. The remaining three digits define the materials of construction. Parts included in the kit are marked with an asterisk in the parts list, for example (201\*). For example, if your pump has polypropylene seats, PTFE balls, and PTFE diaphragms, order Repair Kit **D 0 B 9 1 1**. If you only need to repair certain parts (for example, the diaphragms), use the 0 (null) digits for the seats and balls, and order Repair Kit **D 0 B 0 0 1**. *The digits in the matrix do not correspond to the ref. nos. in the parts drawing and lists on pages 27-28.*

Diaphragm pump	Null	Shaft O-ring	-	Seats	Balls	Diaphragms
D (for all pumps)	0 (for all pumps)	B (PTFE)	-	0 (null)	0 (null)	0 (null)
				-	1 (not used)	1 (PTFE)
				-	2 (not used)	2 (acetal)
				-	3 (316 sst)	3 (not used)
				-	4 (17-4 PH sst)	4 (440C sst)
				-	5 (TPE)	5 (TPE)
				-	6 (Santoprene®)	6 (Santoprene®)
				-	7 (Buna-N)	7 (Buna-N)
				-	8 (Fluoroelastomer)	8 (Fluoroelastomer)
				-	9 (polypropylene)	9 (not used)
				-	A (PVDF)	A (not used)
-	G (Geolast®)	G (Geolast®)				

**Part No. 253627:** Husky 1590 HD Overmolded PTFE/EPDM Diaphragm Repair Kit.

**Part No. 289225:** Husky 1590 HD Overmolded PTFE/EPDM Diaphragm Repair Kit, with new air side diaphragm plates.

**Part No. 24F398:** Husky 1590 PTFE/Santoprene Backer Diaphragm Repair Kit, for metal pumps.

# Parts Drawing

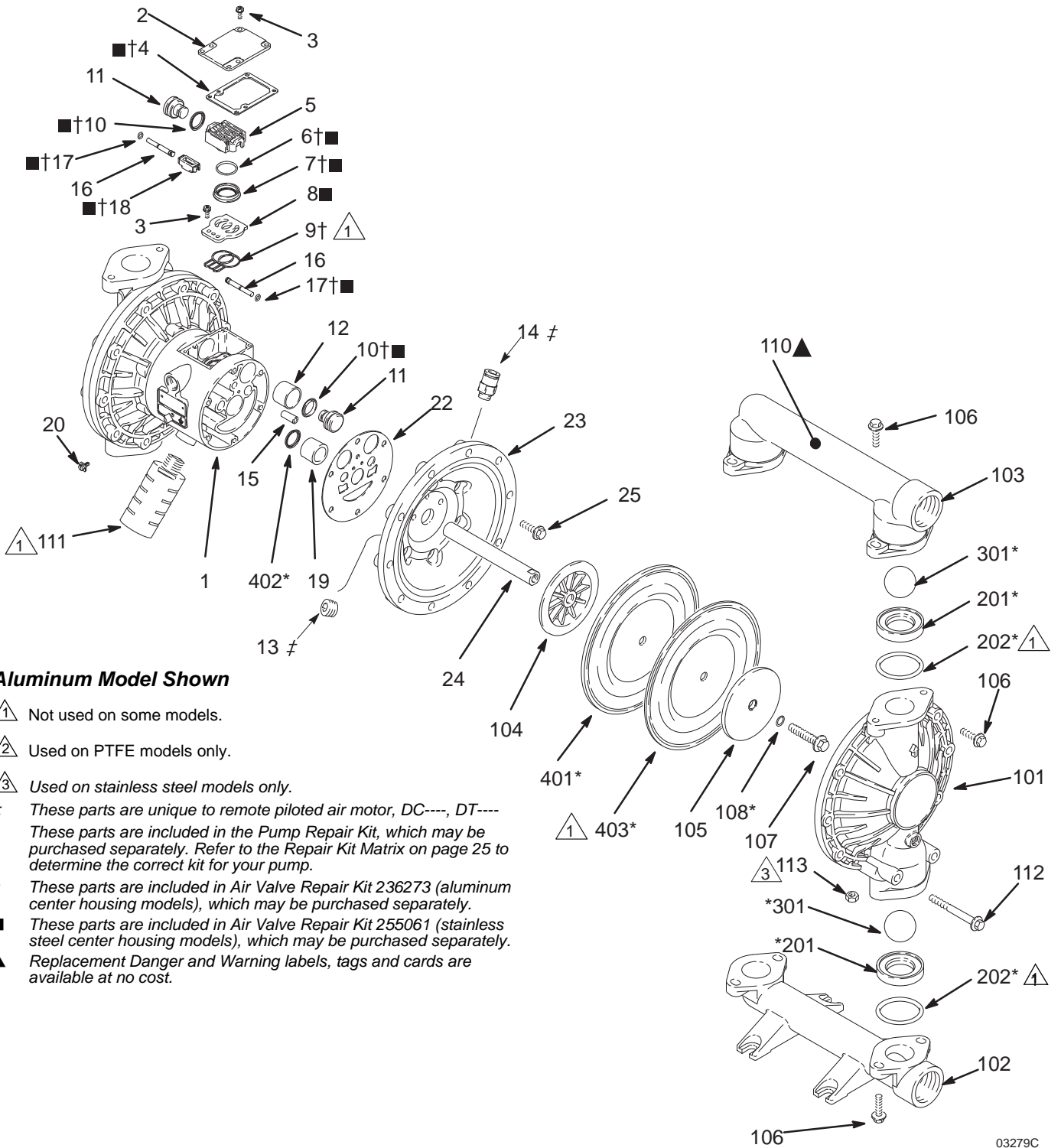

## Aluminum Model Shown

△1 Not used on some models.

△2 Used on PTFE models only.

△3 Used on stainless steel models only.

‡ These parts are unique to remote piloted air motor, DC----, DT----

\* These parts are included in the Pump Repair Kit, which may be purchased separately. Refer to the Repair Kit Matrix on page 25 to determine the correct kit for your pump.

† These parts are included in Air Valve Repair Kit 236273 (aluminum center housing models), which may be purchased separately.

■ These parts are included in Air Valve Repair Kit 255061 (stainless steel center housing models), which may be purchased separately.

▲ Replacement Danger and Warning labels, tags and cards are available at no cost.

03279C

# Parts

## Air Motor Parts List (Matrix Column 2)

Digit	Ref. No.	Part No.	Description	Qty
B	1	188838	HOUSING, center; aluminum	1
	2	188854	COVER, air valve; aluminum	1
	3	116344	SCREW, mach, hex flange hd; M5 x 0.8; 12 mm (0.47 in.)	9
	4†■	188618	GASKET, cover; foam	1
	5	188855	CARRIAGE; aluminum	1
	6†■	108730	O-RING; nitrile	
	7†■	188616	BLOCK, air valve; acetal	1
	8	188615	PLATE, air valve; sst	1
	9†■	188617	SEAL, valve plate; buna-N	1
	10†■	112181	PACKING, u-cup; nitrile	2
	11	188612	PISTON, actuator; acetal	2
	12	188613	BEARING, piston; acetal	2
	13‡	104765	PLUG, pipe; headless	2
	14‡	115671	FITTING, connector; male	2
	15	188611	BEARING, pin; acetal	2
	16	188610	PIN, pilot; stainless steel	2
	17†■	157628	O-RING; buna-N	2
	18†■	188614	BLOCK, pilot; acetal	1
	19	188609	BEARING, shaft; acetal	2
	20	116343	SCREW, grounding	1
	22	188603	GASKET, air cover; foam	2
	23	189400	COVER, air; aluminum	2
	24	189245	SHAFT, diaphragm; sst	1
	25	115643	SCREW; M8 x 1.25; 25 mm (1 in.), aluminum	12

Digit	Ref. No.	Part No.	Description	Qty
C	Same as B with the following exceptions			
	1	195921	HOUSING, center; remote, aluminum	1
	23	195918	COVER, air; remote	2
T	Same as B with the following exceptions			
	1	15K009	HOUSING, center; stainless steel	1
	2	15K696	COVER, air valve; stainless steel	1
	8■	15H178	PLATE, air valve; stainless steel	1
	9	-	-	-
	23	15A739	COVER, air; stainless steel	2
	25	112178	SCREW; M8 x 1.25; 25 mm (1 in.), stainless steel	12
U	Same as B with the following exceptions			
	1	15K011	HOUSING, center; remote, stainless steel	1
	2	15K696	COVER, air valve; stainless steel	1
	8■	15H178	PLATE, air valve; stainless steel	1
	9	-	-	-
	23	15B795	COVER, air; remote, stainless steel	2
	25	112178	SCREW; M8 x 1.25; 25 mm (1 in.), stainless steel	12

# Parts

## Fluid Section Parts List (Matrix Column 3)

Digit	Ref. No.	Part No.	Description	Qty
3	101	15A615	COVER, fluid; aluminum	2
	102	189402	MANIFOLD, inlet; aluminum	1
	103	15A616	MANIFOLD, outlet; aluminum	1
	104	15K448	PLATE, air side; aluminum	2
	105	262026	PLATE, fluid side; carbon steel	2
	106	115644	SCREW; M10 x 1.25; 35 mm (1.38 in.)	24
	107	189410	BOLT; M12 x 1.75; 55 mm (2.17 in.); 316 sst	2
	108*	104319	O-RING; PTFE	2
	110▲	188970	LABEL, warning	1
	111	102656	MUFFLER ( <i>not used on Model No. 253485</i> )	1
	112	115645	SCREW; M10 x 1.50; 90 mm (3.54 in.)	4
	4	101	194169	COVER, fluid; sst
102		194170	MANIFOLD, inlet; sst	1
103		194221	MANIFOLD, outlet; sst	1
104		15K448	PLATE, air side; aluminum	2
105		189309	PLATE, fluid side; sst	2
106		112416	SCREW; M10 x 1.25; 30 mm (1.18 in.); sst	24
107		189410	BOLT; M12 x 1.75; 55 mm (2.17 in.); 316 sst	2
108*		104319	O-RING; PTFE	2
110▲		188621	LABEL, warning	1
111		102656	MUFFLER	1
112		112417	SCREW; M10 x 1.50; 90 mm (3.54 in.); sst	4
7		Same as 4 and includes certification		
8				

Digit	Ref. No.	Part No.	Description	Qty
C	101	15A615	COVER, fluid; aluminum	2
	102	192078	MANIFOLD, inlet; aluminum; BSPT	1
	103	15A658	MANIFOLD, outlet; aluminum; BSPT	1
	104	15K448	PLATE, air side; aluminum	2
	105	262026	PLATE, fluid side; carbon steel	2
	106	115644	SCREW; M10 x 1.25; 35 mm (1.38 in.)	24
	107	189410	BOLT; M12 x 1.75; 55 mm (2.17 in.); 316 sst	2
	108*	104319	O-RING; PTFE	2
	110▲	188970	LABEL, warning	1
	111	102656	MUFFLER	1
	112	115645	SCREW; M10 x 1.50; 90 mm (3.54 in.)	4
	D	101	194169	COVER, fluid; sst
102		195574	MANIFOLD, inlet; sst; BSPT	1
103		195575	MANIFOLD, outlet; sst; BSPT	1
104		15K448	PLATE, air side; aluminum	2
105		189309	PLATE, fluid side; sst	2
106		112416	SCREW; M10 x 1.25; 30 mm (1.18 in.); sst	24
107		189410	BOLT; M12 x 1.75; 55 mm (2.17 in.); 316 sst	2
108*		104319	O-RING; PTFE	2
110▲		188621	LABEL, warning	1
111		102656	MUFFLER	1
112		112417	SCREW; M10 x 1.50; 90 mm (3.54 in.); sst	4
113		114862	NUT, hex, M10, fhn	8
P		Same as D with the following exceptions		
	102	17N132	MANIFOLD, inlet, sst	1
	103	17N154	MANIFOLD, outlet, sst, vertical	1
R	Same as D with the following exceptions			
	102	17N132	MANIFOLD, inlet, sst	1
	103	17N133	MANIFOLD, outlet, sst, horizontal	1

# Parts

## Seat Parts List (Matrix Column 4)

Digit	Ref. No.	Part No.	Description	Qty.
3	201*	189318	SEAT; 316 stainless steel	4
	202*	112418	O-RING; PTFE	4
4	201*	189319	SEAT; 17-4 stainless steel	4
	202*	112418	O-RING; PTFE	4
5	201*	189322	SEAT; TPE	4
	202	None	Not Used	0
6	201*	189320	SEAT; Santoprene	4
	202*	112418	O-RING; PTFE	4
7	201*	15B266	SEAT; Buna-N	4
	202*	None	Not used	0
8	201*	15B264	SEAT; Fluoroelastomer	4
	202*	None	Not used	0
9	201*	193417	SEAT; polypropylene	4
	202*	112418	O-RING; PTFE	4
A	201*	189732	SEAT; PVDF	4
	202*	112418	O-RING; PTFE	4
G	201*	194213	SEAT; Geolast	4
	202*	112418	O-RING; PTFE	4

## Ball Parts List (Matrix Column 5)

Digit	Ref. No.	Part No.	Description	Qty.
1	301*	112419	BALL; PTFE	4
2	301*	112423	BALL; acetal	4
4	301*	112420	BALL; 440C stainless steel	4
5	301*	112831	BALL; TPE	4
6	301*	112421	BALL; Santoprene	4
7	301*	15B490	BALL; Buna-N	4
8	301*	15B489	BALL; Fluoroelastomer	4
G	301*	114752	BALL; Geolast	4

## Diaphragm Parts List (Matrix Column 6)

Digit	Ref. No.	Part No.	Description	Qty.
1	401*	Not sold separately	DIAPHRAGM, backup; polychloroprene (CR)	2
	402*	112181	PACKING, u-cup; nitrile	2
	403*	15K312	DIAPHRAGM; PTFE	2
5	401*	189425	DIAPHRAGM; TPE	2
	402*	112181	PACKING, u-cup; nitrile	2
6	401*	189426	DIAPHRAGM; Santoprene	2
	402*	112181	PACKING, u-cup; nitrile	2
7	401*	15B312	DIAPHRAGM; Buna-N	2
	402*	112181	PACKING, u-cup; nitrile	2
8	401*	15B501	DIAPHRAGM; Fluoroelastomer	2
	402*	112181	PACKING, u-cup; nitrile	2
G	401*	194214	DIAPHRAGM; Geolast	2
	402*	112181	PACKING, u-cup; nitrile	2

\* These parts are included in the pump repair kit, purchased separately. See Repair Kit Matrix on page 26 to determine the correct kit for your pump.

# Torque Instructions

Always follow torque sequence when instructed to torque fasteners.

- 1. Left/Right Fluid Covers  
Torque bolts to 190-220 in-lb (22-25 N•m).

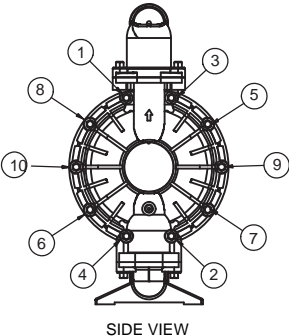

- 2. Inlet Manifold  
Torque bolts to 120-150 in-lb (14-17 N•m).

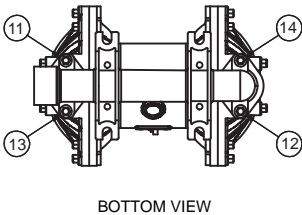

- 3. Outlet Manifold  
Torque bolts to 120-150 in-lb (14-17 N•m).

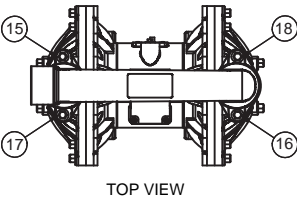

# Dimensions

**FRONT VIEW**

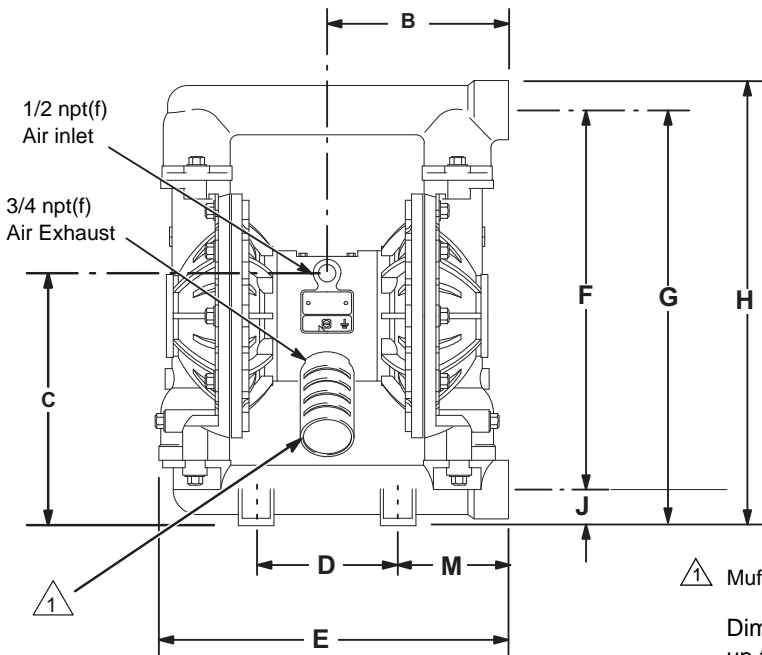

**PUMP MOUNTING HOLE PATTERN**

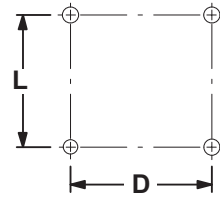

1 Muffler not included on Model No. 253485.

Dimensions B, C, F, G, H and M can vary by up to 1/4 in. (6.3 mm) depending on the seat and diaphragm material fitted in the pump.

**SIDE VIEW**

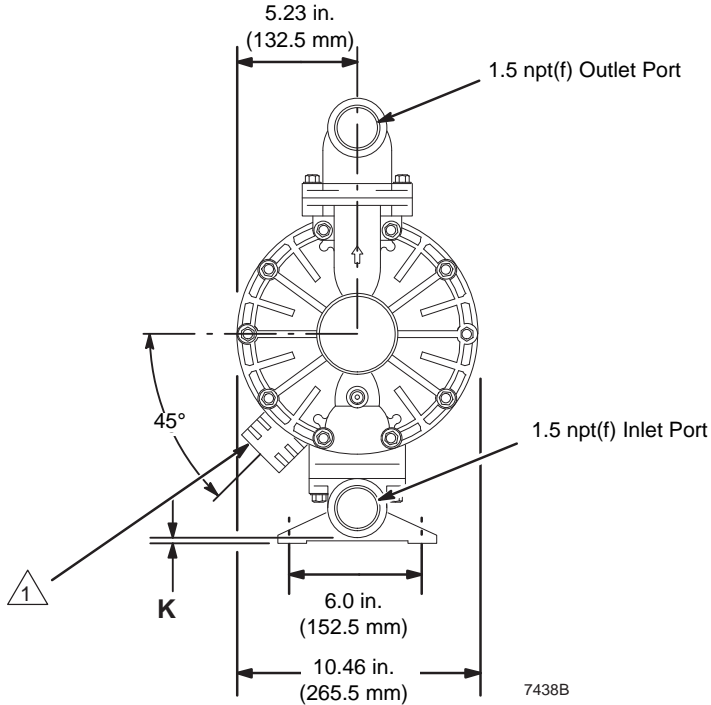



# Pump with Stainless Steel Flanged Manifold Ports

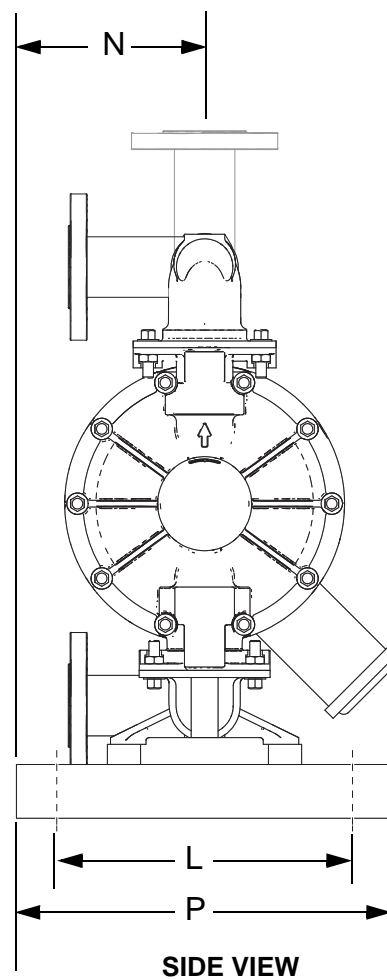
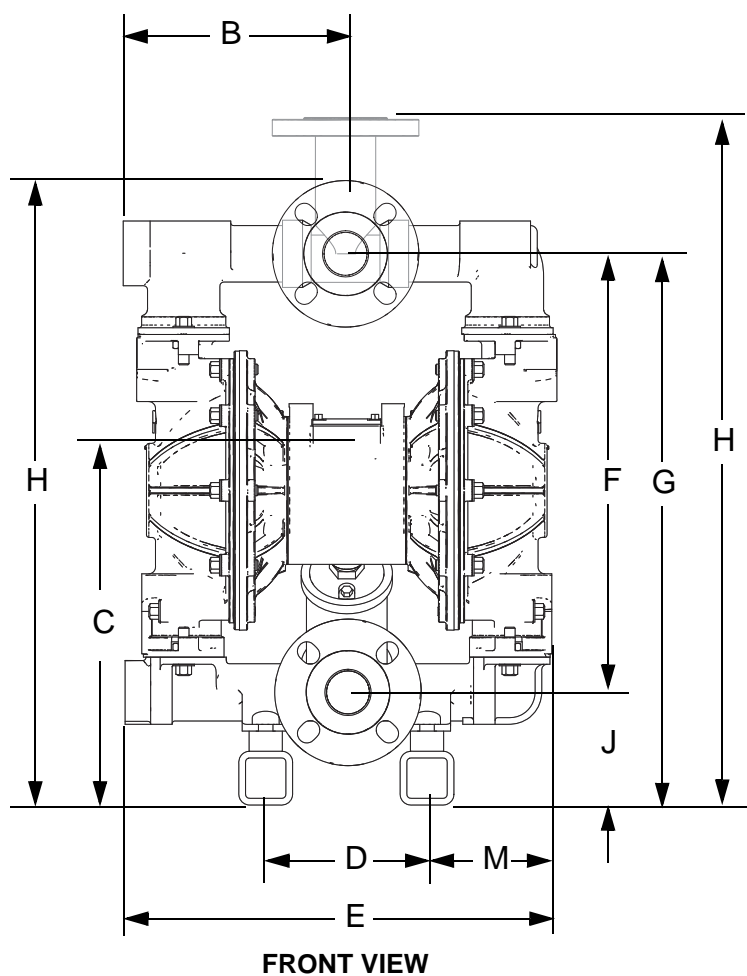

Dimensions B, C, F, G, H and M can vary by up to 1/4 in. (6.3 mm) depending on the seat and diaphragm material fitted in the pump.

# Dimensions

Dimension	Aluminum Center Aluminum Cover		Aluminum Center SST Cover		Aluminum OR SST Center SST Cover Flanged Manifold Ports		SST Center Aluminum Cover		SST Center SST Cover	
	in.	mm	in.	mm	in.	mm	in.	mm	in.	mm
<b>B</b>	7.7	197	8.3	210	8.4	213	7.7	197	8.3	210
<b>C</b>	10.8	273	10.8	273	13.5	343	10.8	273	10.8	273
<b>D</b>	6.0	152	6.0	152	6.0	152	6.0	152	6.0	152
<b>E</b>	15.9	404	15.9	403	15.9	404	15.9	404	15.9	403
<b>F</b>	16.8	427	16.3	414	16.3	414	16.8	427	16.3	141
<b>G</b>	18.3	465	17.8	451	25.5	648	18.3	465	17.8	451
<b>H</b>	19.6	497	19.0	482	23.2/25.6	589/650	19.6	497	19.0	482
<b>J</b>	1.5	38	1.4	37	4.2	107	1.5	38	1.4	37
<b>K</b>	0.25	6	0.25	6	---	---	0.25	6	0.25	6
<b>L</b>	6.0	152	6.0	152	11.0	279	6.0	152	6.0	152
<b>M</b>	4.8	121	5.2	133	4.6	117	4.8	121	5.2	133
<b>N</b>	---	---	---	---	7.0	178	---	---	---	---
<b>P</b>	---	---	---	---	14.0	356	---	---	---	---

†Dimension H for flanged port manifolds represent both the horizontal and vertical outlet manifold port dimensions.

# Technical Data

Maximum fluid working pressure . . . . .	120 psi (0.8 MPa, 8 bar)
Air pressure operating range . . . . .	20-120 psi (0.14 -0.8 MPa, 1.4-8 bar)
Maximum air consumption . . . . .	125 scfm
Air consumption at 70 psi/60 gpm . . . . .	50 scfm (see chart)
Maximum free-flow delivery . . . . .	100 gpm (378.5 l/min)
Maximum pump speed . . . . .	200 cpm
Gallons (Liters) per cycle . . . . .	0.5 (1.9)
Maximum suction lift . . . . .	18 ft (5.48 m) wet or dry
Maximum size pumpable solids . . . . .	3/16 in. (4.8 mm)
* Maximum noise level at 100 psi, full flow . . . . .	94 dBa
* Sound power level . . . . .	108 dBa
* Noise level at 70 psi, 50 cycles/min . . . . .	72 dBa
Maximum operating temperature . . . . .	150°F (65.5°C); 200°F (93.3°C) for models with PTFE diaphragms
Air inlet size . . . . .	0.5 npt(f)
Fluid inlet size . . . . .	1.5 npt(f)
Fluid outlet size . . . . .	1.5 npt(f)
Wetted parts . . . . .	Vary by Model. See pages 24-27.
Non-wetted external parts . . . . .	aluminum, 302, 316 stainless steel, polyester (labels)
Weight	
Aluminum pumps . . . . .	33.5 lb (15.2 kg)
Stainless steel pumps with aluminum center section . . . . .	71 lb (32.7 kg)
Stainless steel pumps with aluminum center section and flanged port manifolds . . . . .	96 lb (43.5 kg)
Stainless steel pumps with stainless steel center section . . . . .	86 lb (40 kg)
Stainless steel pumps with stainless steel center section and flanged port manifolds . . . . .	111lb (50.3 kg)

Geolast® is a registered trademarks of the ExxonMobil Chemical Co.

Santoprene® is a registered trademarks of the Monsanto Co.

\* Noise levels measured with the pump mounted on the floor, using Rubber Foot Kit 236452. Sound power measured per ISO Standard 9216.

# Performance Chart

## Example of Finding Pump Air Consumption and Air Pressure at a Specific Fluid Delivery and Discharge Head:

To supply 60 gpm (227 liters) fluid flow (horizontal scale) at 40 psi (0.28 MPa, 2.8 bar) discharge head pressure (vertical scale) requires approximately 50 scfm (1.40 m<sup>3</sup>/min) air consumption at 70 psi (0.49 MPa, 4.9 bar) inlet air pressure.

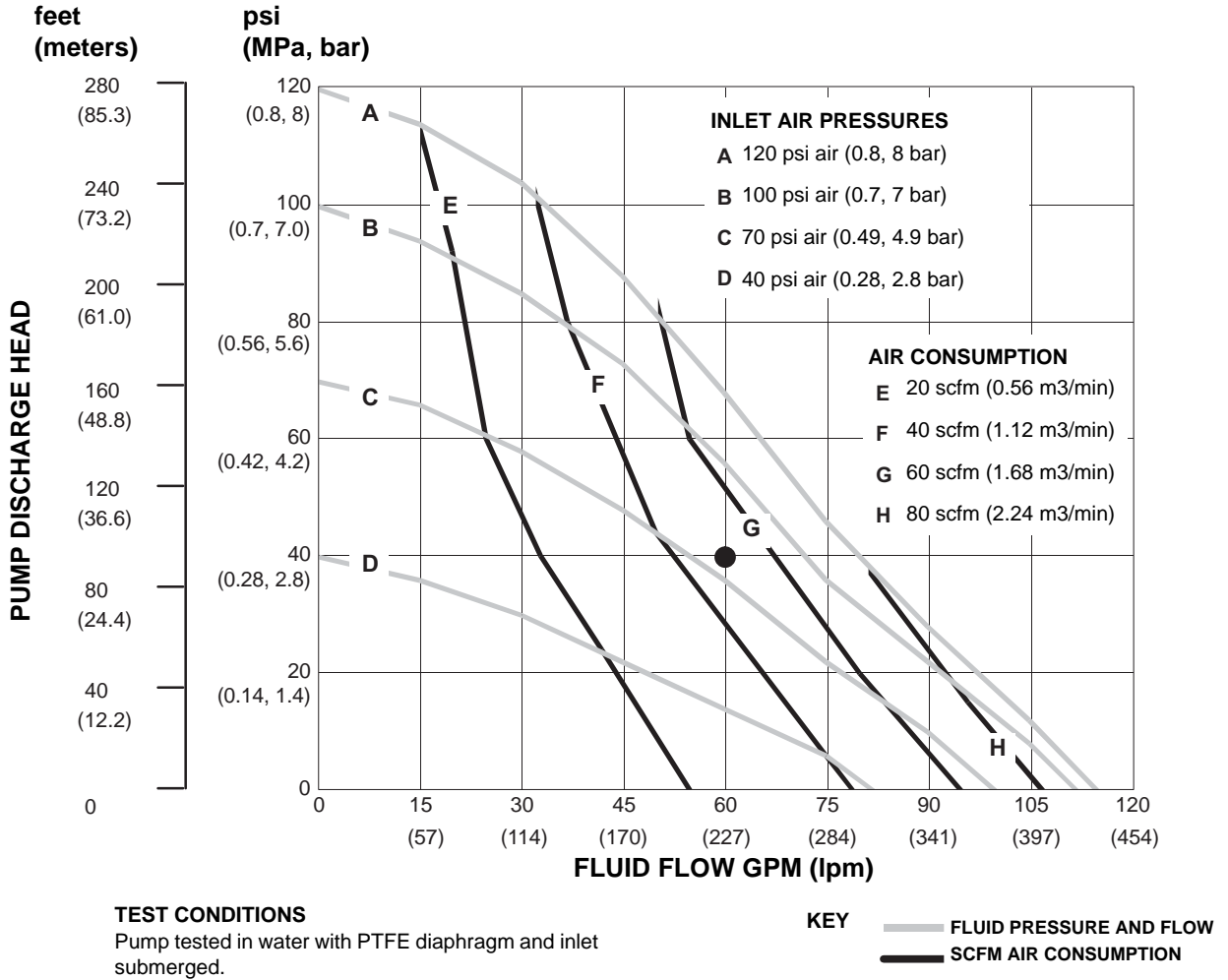



# Graco Standard Husky Pump Warranty

Graco warrants all equipment referenced in this document which is manufactured by Graco and bearing its name to be free from defects in material and workmanship on the date of sale to the original purchaser for use. With the exception of any special, extended, or limited warranty published by Graco, Graco will, for a period of twelve months from the date of sale, repair or replace any part of the equipment determined by Graco to be defective. This warranty applies only when the equipment is installed, operated and maintained in accordance with Graco's written recommendations.

This warranty does not cover, and Graco shall not be liable for general wear and tear, or any malfunction, damage or wear caused by faulty installation, misapplication, abrasion, corrosion, inadequate or improper maintenance, negligence, accident, tampering, or substitution of non-Graco component parts. Nor shall Graco be liable for malfunction, damage or wear caused by the incompatibility of Graco equipment with structures, accessories, equipment or materials not supplied by Graco, or the improper design, manufacture, installation, operation or maintenance of structures, accessories, equipment or materials not supplied by Graco.

This warranty is conditioned upon the prepaid return of the equipment claimed to be defective to an authorized Graco distributor for verification of the claimed defect. If the claimed defect is verified, Graco will repair or replace free of charge any defective parts. The equipment will be returned to the original purchaser transportation prepaid. If inspection of the equipment does not disclose any defect in material or workmanship, repairs will be made at a reasonable charge, which charges may include the costs of parts, labor, and transportation.

**THIS WARRANTY IS EXCLUSIVE, AND IS IN LIEU OF ANY OTHER WARRANTIES, EXPRESS OR IMPLIED, INCLUDING BUT NOT LIMITED TO WARRANTY OF MERCHANTABILITY OR WARRANTY OF FITNESS FOR A PARTICULAR PURPOSE.**

Graco's sole obligation and buyer's sole remedy for any breach of warranty shall be as set forth above. The buyer agrees that no other remedy (including, but not limited to, incidental or consequential damages for lost profits, lost sales, injury to person or property, or any other incidental or consequential loss) shall be available. Any action for breach of warranty must be brought within two (2) years of the date of sale.

**GRACO MAKES NO WARRANTY, AND DISCLAIMS ALL IMPLIED WARRANTIES OF MERCHANTABILITY AND FITNESS FOR A PARTICULAR PURPOSE, IN CONNECTION WITH ACCESSORIES, EQUIPMENT, MATERIALS OR COMPONENTS SOLD BUT NOT MANUFACTURED BY GRACO.** These items sold, but not manufactured by Graco (such as electric motors, switches, hose, etc.), are subject to the warranty, if any, of their manufacturer. Graco will provide purchaser with reasonable assistance in making any claim for breach of these warranties.

In no event will Graco be liable for indirect, incidental, special or consequential damages resulting from Graco supplying equipment hereunder, or the furnishing, performance, or use of any products or other goods sold hereto, whether due to a breach of contract, breach of warranty, the negligence of Graco, or otherwise.

## **FOR GRACO CANADA CUSTOMERS**

The Parties acknowledge that they have required that the present document, as well as all documents, notices and legal proceedings entered into, given or instituted pursuant hereto or relating directly or indirectly hereto, be drawn up in English. Les parties reconnaissent avoir convenu que la rédaction du présent document sera en Anglais, ainsi que tous documents, avis et procédures judiciaires exécutés, donnés ou intentés, à la suite de ou en rapport, directement ou indirectement, avec les procédures concernées.

## Graco Information

For the latest information about Graco products, visit [www.graco.com](http://www.graco.com).

For patent information, see [www.graco.com/patents](http://www.graco.com/patents).

**TO PLACE AN ORDER**, contact your Graco distributor or call to identify the distributor closest to you:

**Phone:** 612-623-6921 or **Toll Free:** 1-800-328-0211 **Fax:** 612-378-3505

*All written and visual data contained in this document reflects the latest product information available at the time of publication.  
Graco reserves the right to make changes at any time without notice.*

Original instructions. This manual contains English. MM 308441

**Graco Headquarters:** Minneapolis

**International Offices:** Belgium, China, Japan, Korea

**GRACO INC. P.O. BOX 1441 MINNEAPOLIS, MN 55440-1441**

Copyright 1995, Graco Inc. is registered to ISO 9001

[www.graco.com](http://www.graco.com)

Revision ZAK, March 2017