

PART NO.	DIMENSIONS						WEIGHT	
	"A" NOM. IN. MM	"B" IN. MM	"C" IN. MM	"D" IN. MM	"E" IN. MM	"F" IN. MM	LBS	KGS
1.31LSTN	1 / 25	19.00 / 483	8.00 / 203	5.56 / 141	6.75 / 171	0.81 / 21	62 / 28.1	
1.2531LSTN	1.25 / 30	19.00 / 483	8.00 / 203	5.56 / 141	6.75 / 171	0.81 / 21	62 / 28.1	
1.531LSTN	1.5 / 40	19.00 / 483	8.00 / 203	5.56 / 141	6.75 / 171	0.81 / 21	61 / 27.7	
2.31LSTN	2 / 50	18.00 / 457	8.00 / 203	5.56 / 141	6.75 / 171	0.81 / 21	60 / 27.2	
2.531LSTN	2.5 / 65	22.75 / 578	9.00 / 229	7.63 / 194	6.75 / 171	0.81 / 21	92 / 41.7	
3.31LSTN	3 / 75	21.00 / 533	9.00 / 229	7.63 / 194	6.75 / 171	0.81 / 21	90 / 40.8	

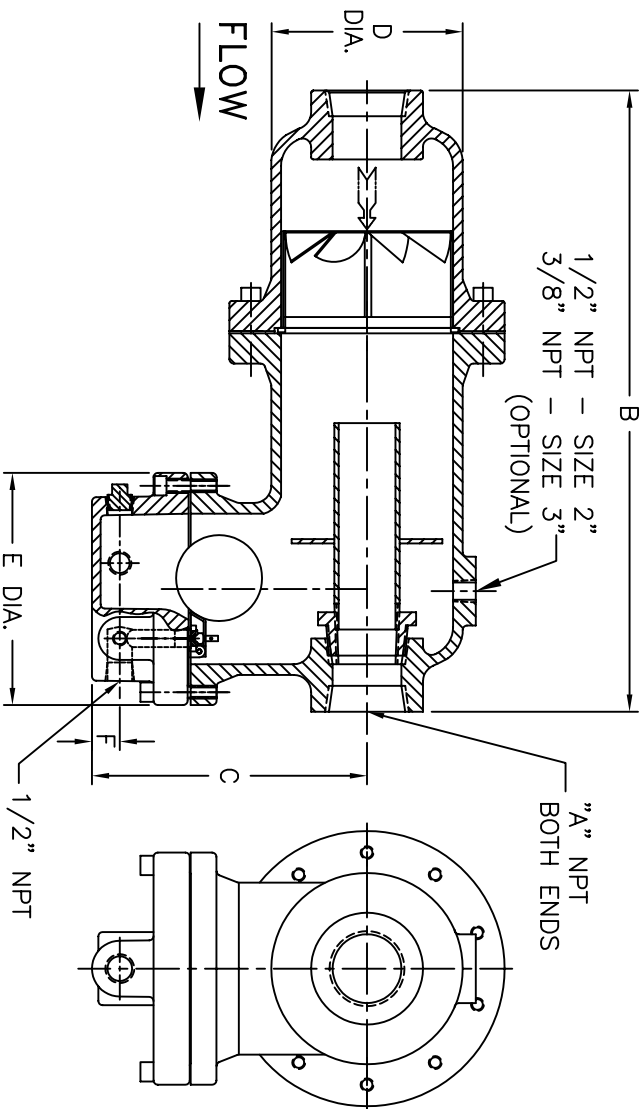

NOTES:

1. ALL DIMENSIONS ARE IN INCHES [MM].
2. DESIGN DATA:

DESIGN PRESSURE- 250 PSIG [17.2 BARS]
 DESIGN TEMPERATURE- 450° F [232.2 °C]
 MIN. DESIGN METAL TEMP.- -20° F @ 250 PSIG
 [-28.9° C @ 17.2 BARS]

3. MATERIAL: BODY & COVER - CAST IRON, SA-278 CLASS 30
 INTERNALS - STAINLESS STEEL
 GASKET - NON-ASBESTOS
4. REDUCER BUSHING USED ON 2-1/2", 1-1/2", 1-1/4" & 1" CONNECTION.

CERTIFIED FOR:

P.O. NO.:
 S.O. NO.:
 QUOTE NO.:
 TAG NO.:

ELECTRONIC FILE NAME: SD31LSTN.DWG
 REF. ECR D507
 DATE 10/18/05

UNAUTHORIZED USE, MANUFACTURE OR
 REPRODUCTION IN WHOLE OR IN PART IS
 PROHIBITED. DRAWING, DESIGN AND
 OTHER DISCLOSURES PROPERTY OF
 EATON FILTRATION, LLC



EATON FILTRATION, LLC
 900 FAIRMOUNT AVENUE, ELIZABETH, NEW JERSEY 07207

NAME TYPE 31L-ST GAS / LIQUID
 SEPARATOR - TRAP
 SIZES 1" - 3" NPT CAST IRON

DRAWN FM DATE 6/24/04 CERT. VAA DATE 6/25/04

SIZE
 A

DWG
 NO

SD31LSTN

REV
 E