

BLACKMER PARTS LIST

PUMP MODEL: X2B

Keep with Instructions 101-B00 for Installation, Operation and Maintenance

Section 101
Effective Feb 2014
Replaces Apr 2012

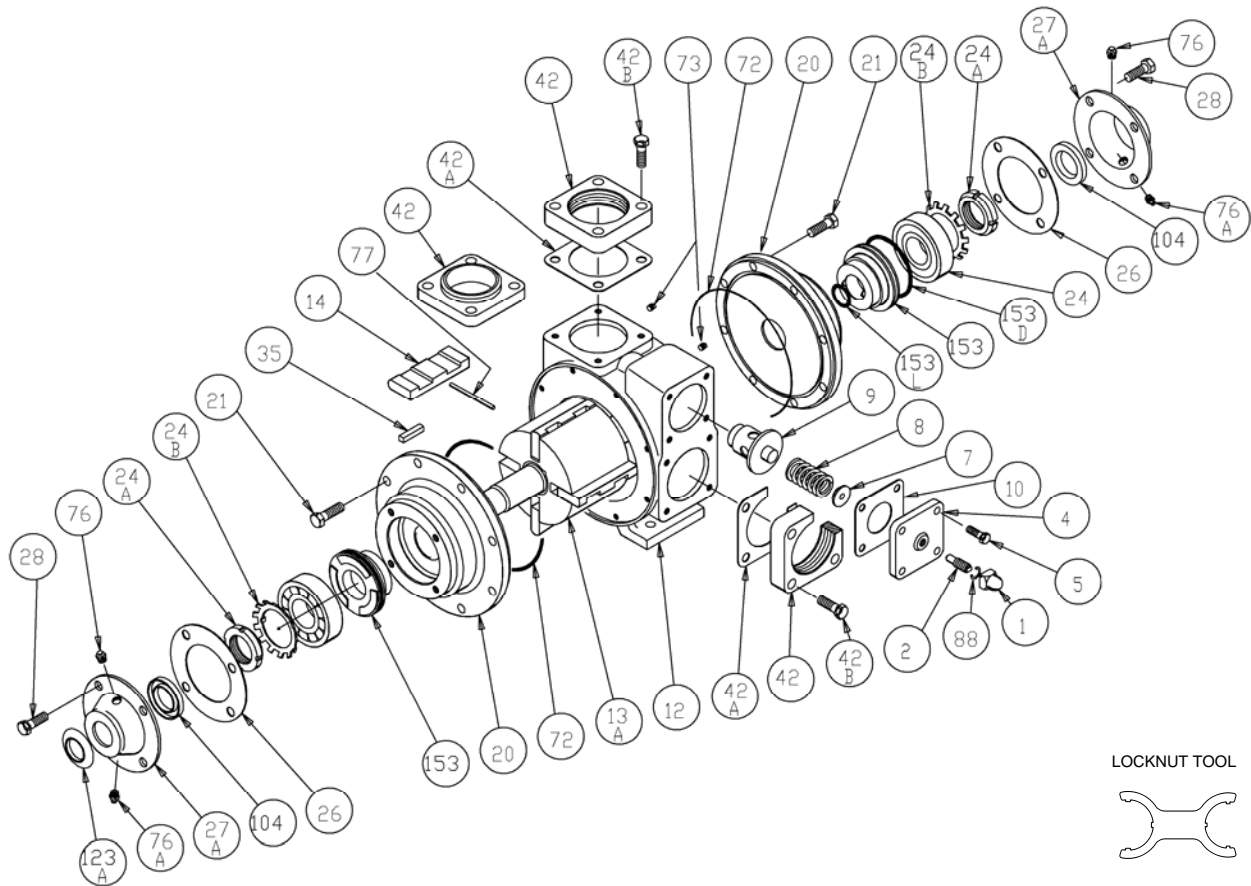

Ref. No.	Description	Parts per Pump	Part No.	Ref. No.	Description	Parts per Pump	Part No.
1	Cap - Relief Valve (R/V)	1	411453	24A	Locknut - Bearing	2	⁴ 903521
2	Adjusting Screw - R/V	1	431401	24B	Lock Washer - Bearing	2	⁴ 903522
4	Cover - R/V	1	411401	26	Gasket - Bearing Cover	2	¹ 383940
5	Capscrew - R/V Cover	4	920316	27	Bearing Cover - Outboard	1	041433
7	Spring Guide - R/V	1	423955	27A	Bearing Cover - Inboard	1	041431
8	Spring - R/V (36-50 psi)	1	471415	28	Capscrews - Bearing Cover	8	920285
	Spring - R/V (51-75 psi)		471420	35	Key - Shaft, Square	1	^{1,2} 909209
	Spring - R/V (76-110 psi)		471425	42	Flange - 2" NPT (Std.)*	2	651411
	Spring - R/V (111-125 psi)		471428	42A	Gasket - NPT Flange (Std.)	2	¹ 381421
	SS Spring - R/V (76-110 psi)		471427	42B	Capscrews - NPT Flange (Std.)	8	920351
9	Valve - R/V (Std.)	1	451417	72	O-Ring - Head (FKM) (Std.)	2	¹ 701914
	Valve - R/V (Nickel Plated)		451415		O-Ring - Head (PTFE)		702242
10	Gasket - R/V Cover	1	¹ 531403		O-Ring - Head (Buna-N)		701947
12	Cylinder	1	021403	73	Gage Plug	2	908198
13	Rotor & Shaft	1	³ 261426	76	Grease Fitting	2	317815
14	Vane - Duravane (Std.)	4	¹ 091419	76A	Grease Relief Fitting	2	701992
	Vane - EC Cast Iron		093923	77	Push Rod	2	¹ 123905
	Vane - EC Laminate		091429	88	Gasket - R/V Cap	1	¹ 701981
20	Head	2	031425	104	Grease Seal	1	¹ 331918
21	Capscrews - Head	16	920331	123A	Dirt Shield	1	¹ 701480
24	Ball Bearing	2	¹ 903156		Kit - Maintenance		898956
					Tool - Locknut		903091

¹ Included in Maintenance Kit ² Maintenance Kit also includes Woodruff Key 909130 used previously
³ Includes 24A & 24B * See Page 2 for Weld & ANSI flange options. SS = Stainless Steel. EC = Extra-Clearance.
⁴ Earlier models are not fitted with locknuts and lock washers.
The current rotor / shaft with locknuts and lock washers may be fitted in place of shafts without locknuts and lock washers.

MECHANICAL SEALS

Ref. No.	Part Name	Parts Per Pump	Part No.
153	Mechanical Seal Complete - (Std.) Cast Iron Stationary Seat, Carbon Seal Face, FKM O-Rings. (IVCV)	2	¹ 331655
	Mechanical Seal Complete - Cast Iron Stationary Seat, PTFE O-Ring, Carbon Seal Face w/ PTFE Seal Ring. (IACT)		331673
	Mechanical Seal Complete - Stainless Steel Stationary Seat, PTFE O-Ring, Carbon Seal Face w/ PTFE Seal Ring. (WACT)		331648
	Mechanical Seal Complete - Cast Iron Stationary Seat, Carbon Seal Face, Buna-N O-Rings. (INCN)		331601
153D	O-Ring - Stationary (FKM)	2	701921
	O-Ring - Stationary (PTFE)		702056
	O-Ring - Stationary (Buna-N)		701934
153L	O-Ring - Rotating (FKM)	2	701980
	Seal Ring - Rotating (PTFE)		**
	O-Ring - Rotating (Buna-N)		701922

¹ Included in Maintenance Kit

**PTFE Rotating Seal Ring is not available as a separate part.

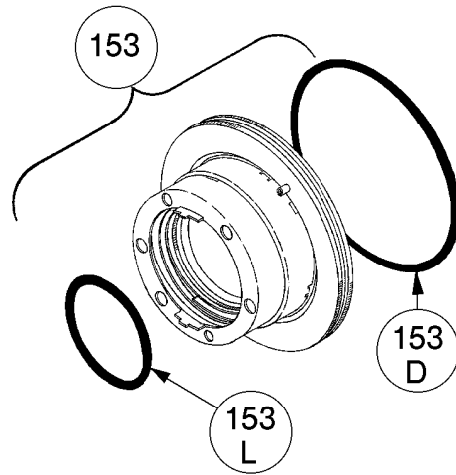

FLANGE OPTIONS

Ref. No.	Part Name	Parts Per Pump	Part No.
42	Flange - 2" Weld	2	654405
	Flange - 2" ANSI		651417
42B	Capscrews - Weld / ANSI Flange	8	920384
42C	O-Ring - Weld/ANSI Flange (FKM)	2	701921
	O-Ring - Weld/ANSI Flange(PTFE)		702056
	O-Ring - Weld/ANSI Flange(Buna-N)		701934

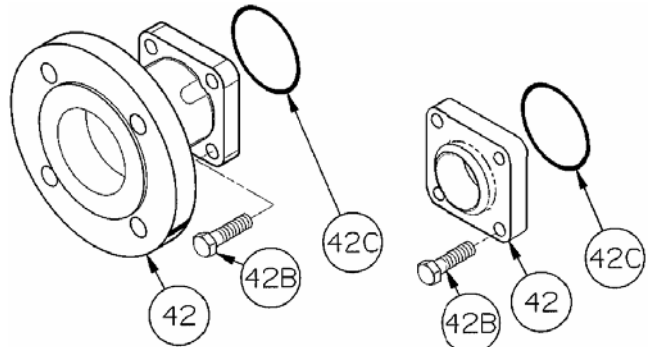

ANSI FLANGE

WELD FLANGE

