

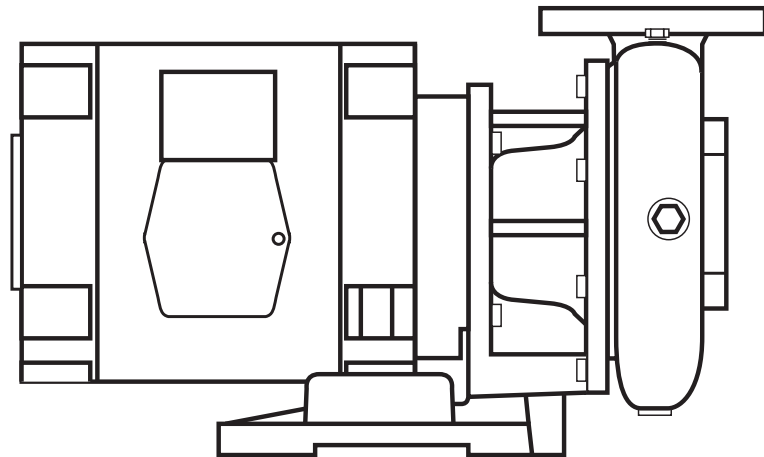

**AURORA®**



# 340A SERIES

## REPAIR PARTS INDEX

NOTE! Read and understand the pump and motor instructions before attempting to install, disassemble or repair the pump.

**TABLE OF CONTENTS**

<b>PUMP MODEL</b>	<b>DESCRIPTION</b>	<b>PAGE</b>
340A Series	Repair Parts Index.....	3
341A	Horizontal Close Coupled Exploded view and piece numbers.....	4
342A	Vertical Close Coupled Exploded view and piece numbers.....	5
344A	Horizontal Power Frame Mounted Exploded view and piece numbers.....	6

<b>PUMP SIZE</b>	<b>PAGE</b>
1-1/4 x 1-1/2 x 7 through 4 x 4 x 7B Part Numbers.....	7 – 9
1-1/4 x 1-1/2 x 9B through 6 x 6 x 9 Part Numbers.....	10 – 12
1-1/2 x 2 x 11 through 6 x 6 x 11A Part Numbers.....	13 – 15
1-1/2 x 2 x 12 through 6 x 6 x 12A Part Numbers.....	16 – 18

Refer to Notes 1 and 2 for Models 341A and 342A Close Coupled Pumps.

**NOTES:**

- 1) Part numbers 9, 10, 11, 12, 25 and 27 are listed with a letter **(S)** or **(L)** indicating the small or large shaft used to build the 340A series pumps.
- 2) To determine when to use **(S)** or **(L)** parts, in addition to the pump size, it is also necessary to have the close coupled motor frame number for 341A and 342A pumps. Motor frame 215JM and smaller use **(S)** parts. Motor frame 254JM and larger use **(L)** parts.
- 3) For 344A power frame assignment, refer to chart at left.
- 4) Liquid end maintenance kits may be found on pages 8, 11, 14 and 17 of this manual or in the current repair part kits manual.
- 5) Casings and brackets for pumps manufactured prior to 4/76 are no longer available for models 341, 342 and 344. Both the current bracket and casing are required for these older pumps if a replacement is required.
- 6) Part numbers are shown for bronze fitted and all iron pumps. Standard fitted pumps are the same as bronze fitted except that the impeller only is cast iron rather than bronze.

**REPAIR PARTS INDEX**

**THIS CHART FOR USE WITH MODEL 344A PUMPS ONLY TO DETERMINE  
POWER FRAME SIZE BASED ON THE PUMP SIZE AND OPERATING SPEED.**

<b>PUMP SIZE</b>	<b>3500</b>	<b>1750</b>	<b>1150</b>
1-1/4 x 1-1/2 x 7	1	1	-
1-1/4 x 1-1/2 x 9B	-	1	-
1-1/2 x 2 x 7	1	1	-
1-1/2 x 2 x 9A	-	1	-
1-1/2 x 2 x 9B	-	1	-
1-1/2 x 2 x 9C	2	1	-
1-1/2 x 2 x 11	3	2	2
1-1/2 x 2 x 12	-	2	2
2 x 2-1/2 x 7A	2	1	-
2 x 2-1/2 x 7B	1	1	-
2 x 2-1/2 x 9	3	1	-
2 x 2-1/2 x 12	-	2	2
2 x 3 x 11	-	2	2
2-1/2 x 3x 7A	1	1	-
2-1/2 x 3 x 7B	2	1	-
2-1/2 x 3 x 9	3	1	-
2-1/2 x 3 x 12	-	2	2
3 x 4 x 9A	3	1	-
3 x 4 x 9B	3	1	-
3 x 4 x 11	-	2	2
3 x 4 x 12	-	3	2
4 x 4 x 7A	2	1	-
4 x 4 x 7B	2	1	-
4 x 5 x 9A	3	2	-
4 x 5 x 9B	-	2	-
4 x 5 x 11	-	2	2
4 x 5 x 12	-	3	2
5 x 6 x 11	-	3	2
5 x 6 x 12	-	3	2
6 x 6 x 9	-	2	2
6 x 6 x 11	-	3	2
6 x 6 x 11A	-	3	2
6 x 6 x 12	-	3	3
6 x 6 x 12A	-	3	-

Power Frame #1 – use **(S)** parts.

Power Frame #2 – use **(L)** parts.

Power Frame #3 – use **(L)** parts.

MODEL 341A  
PIECE NUMBERS

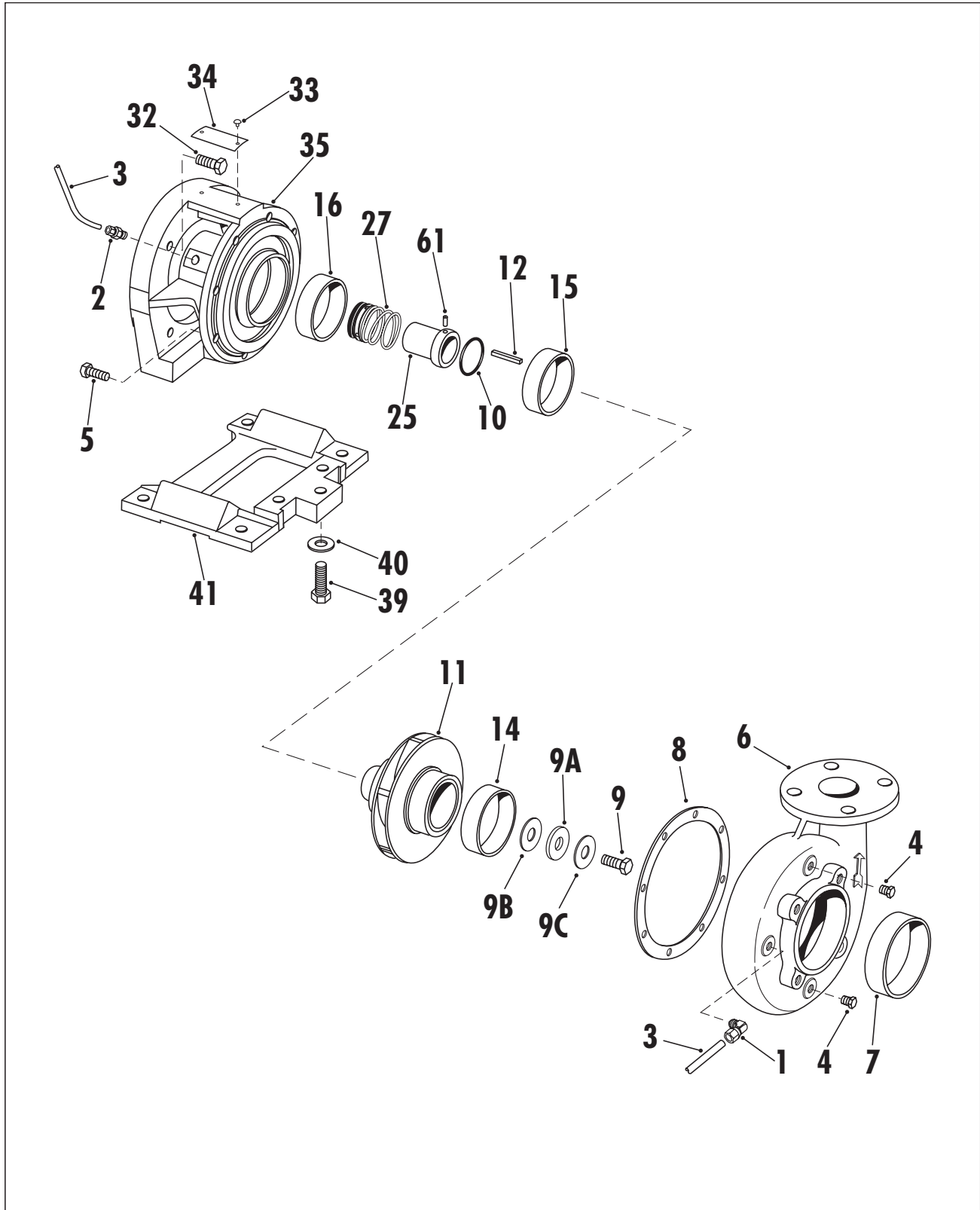

MODEL 342A  
PIECE NUMBERS

SUPERSEDES 340P PAGE 5  
DATED AUGUST 2013

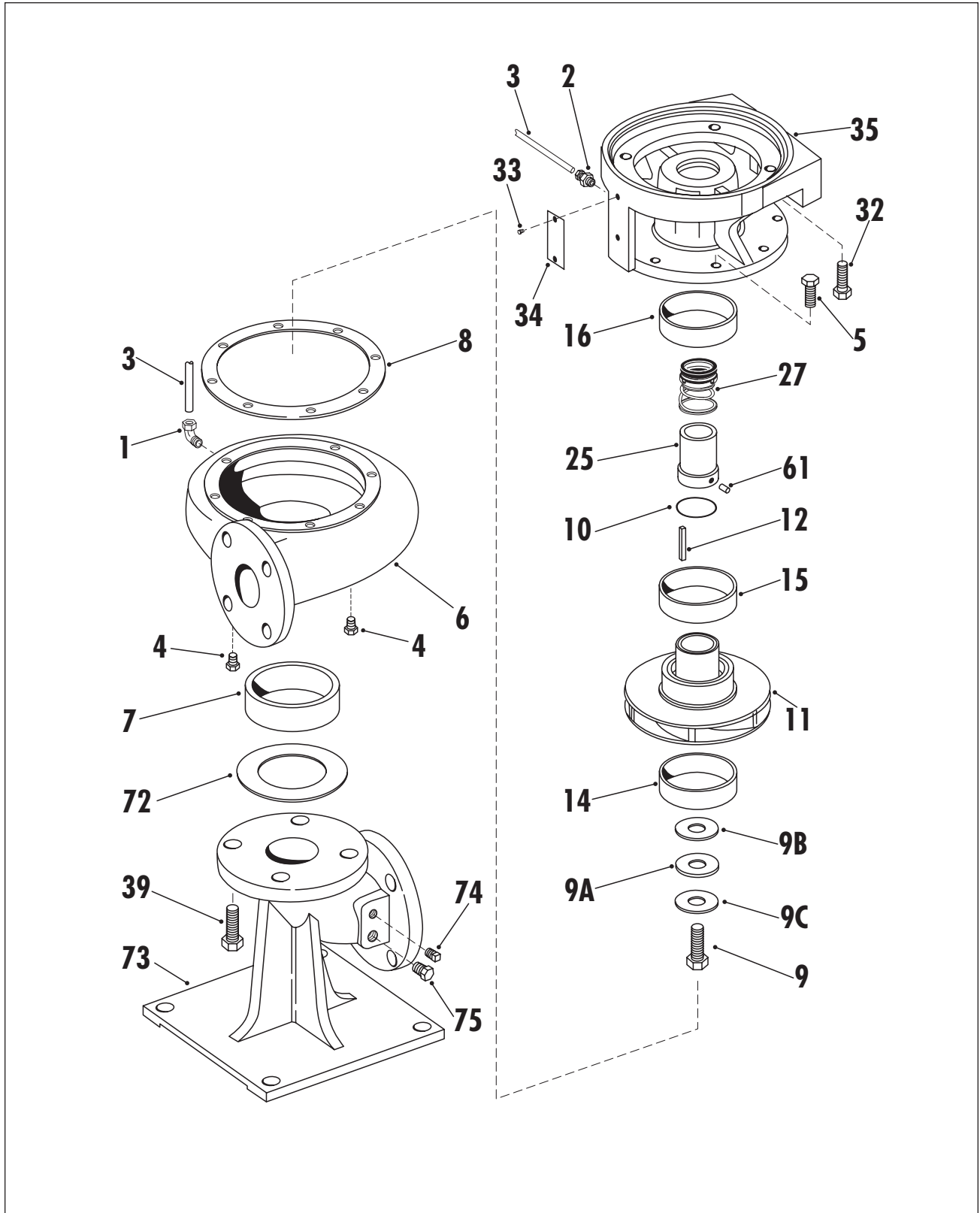

MODEL 344A  
PIECE NUMBERS

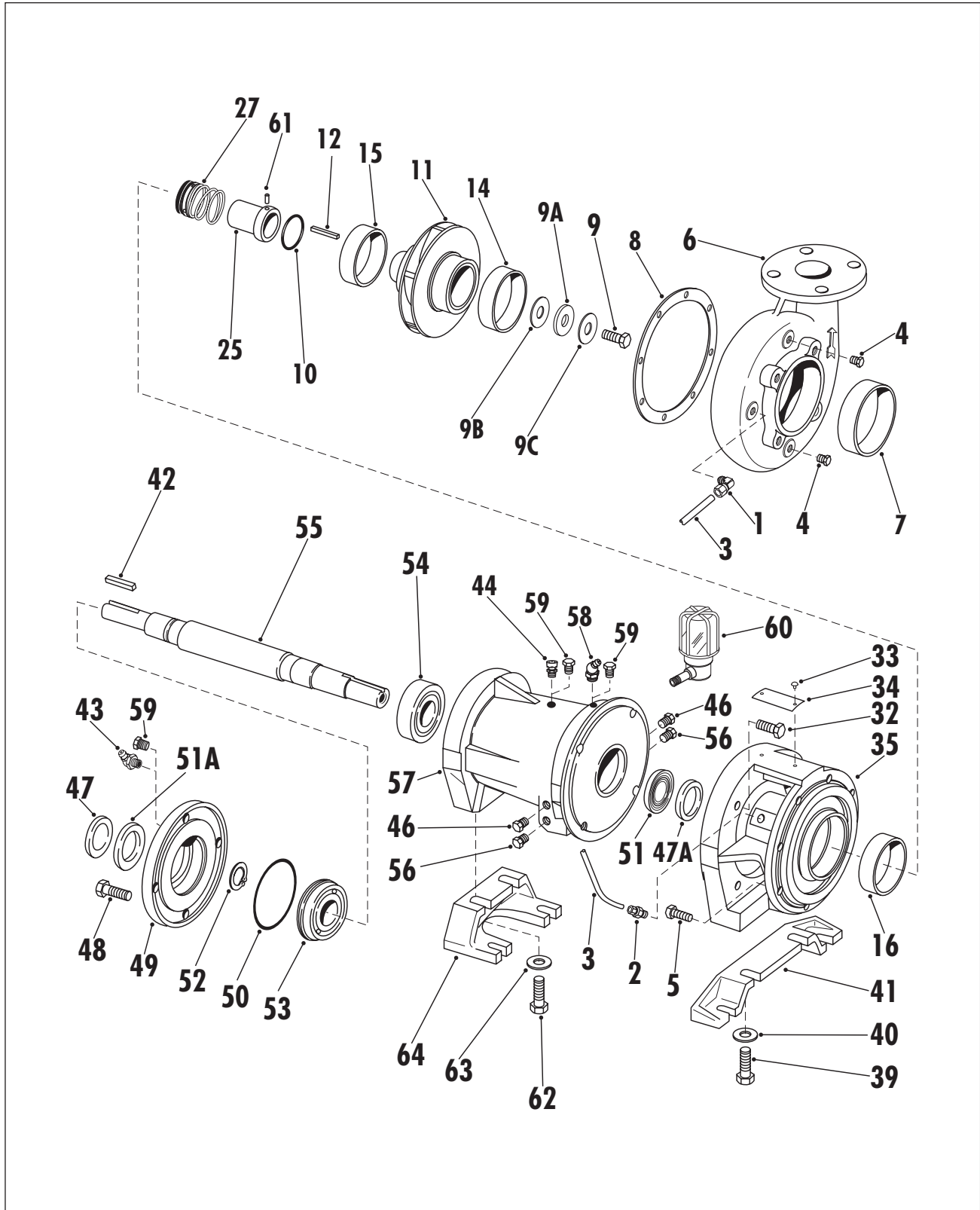

**AURORA® 340A SERIES**  
**MODELS 341A - 342A- 344A**  
**1-1/4 x 1-1/2 x 7 – 4 x 4 x 7B**

SECTION 340P PAGE 7  
 DATED MARCH 2014  
 SUPERSEDES 340P PAGE 7  
 DATED AUGUST 2013

**PARTS LIST**

PC. NO.	DESCRIPTION	QTY	PART NO.	MATERIAL			
				B.F.		A.I.	
1	COMPRESSION ELBOW	1	868-3660	190		087	
2	COMPRESSION CONNECTOR	1	868-3359	190		087	
3	TUBING	1	872-0124	175		087	
4	PIPE PLUG	3	600-0002	087		087	
5	CAPSCREW	8	168-0381	082		082	
6	CASING						
	1-1/4 x 1-1/2 x 7	1	180-2138	010		010	
	1-1/2 x 2 x 7	1	180-2140	010		010	
	2 x 2-1/2 x 7A & B	1	180-2142	010		010	
	2-1/2 x 3 x 7A & B	1	180-2144	010		010	
	4 x 4 x 7A & B	1	180-2146	010		010	
	VERTICAL						
1-1/4 x 1-1/2 x 7	1	180-2196	010		010		
1-1/2 x 2 x 7	1	180-2197	010		010		
7	CASE RING						
	1-1/4 x 1-1/2 x 7	1	676-1150	208		010	
	1-1/2 x 2 x 7	1	676-1151	208		010	
	2 x 2-1/2 x 7A & B	1	676-1152	208		010	
	2-1/2 x 3 x 7A & B	1	676-1152	208		010	
	4 x 4 x 7A & B	1	676-1154	208		010	
8	GASKET	1	364-1014	603		603	
9	CAPSCREW (S) (L)	1	168-0382	113		113	
		1	168-0490	113		113	
9A	WASHER (S) (L)	1	908-0603	087		087	
		1	908-0604	087		087	
9B	GASKET (S) (L)	1	364-2034	603		603	
		1	364-2035	603		603	
9C	CAPSCREW SEAL (S) (L)	1	908-1290	999		999	
		1	908-1292	999		999	
10	O-RING (S) (L)	1	364-0409	457		457	
		1	364-0414	457		457	
11	IMPELLER (S)						
		1-1/4 x 1-1/2 x 7	1	443-0407	225		010
		1-1/2 x 2 x 7	1	443-0409	225		010
		2 x 2-1/2 x 7A	1	443-0411	225		010
		2 x 2-1/2 x 7B	1	443-0415	225		010
		2-1/2 x 3 x 7A	1	443-2034	225		010
		2-1/2 x 3 x 7B	1	443-0417	225		010
		4 x 4 x 7A	1	443-0425	225		010
		4 x 4 x 7B	1	443-0423	225		010
		IMPELLER (L)					
	2 x 2-1/2 x 7A		1	443-0413	225		010
	2-1/2 x 3 x 7A		1	443-2035	225		010
	2-1/2 x 3 x 7B		1	443-0419	225		010
	4 x 4 x 7A	1	443-0427	225		010	
4 x 4 x 7B	1	443-0472	225		010		
11A	IMPELLER (S)*						
		1-1/4 x 1-1/2 x 7	1	443-0408	225		010
		1-1/2 x 2 x 7	1	443-0410	225		010
		2 x 2-1/2 x 7A	1	443-0412	225		010
		2 x 2-1/2 x 7B	1	443-0416	225		010
		2-1/2 x 3 x 7A	1	443-1775	225		010

PC. NO.	DESCRIPTION	QTY	PART NO.	MATERIAL			
				B.F.		A.I.	
11A	IMPELLER (S)* 2-1/2 x 3 x 7B 4 x 4 x 7A 4 x 4 x 7B						
		1	443-0418	225		010	
		1	443-0426	225		010	
		1	443-0424	225		010	
11A	IMPELLER (L)* 2 x 2-1/2 x 7A 2-1/2 x 3 x 7A 2-1/2 x 3 x 7B 4 x 4 x 7A 4 x 4 x 7B						
		1	443-0414	225		010	
		1	443-1776	225		010	
		1	443-0420	225		010	
		1	443-0428	225		010	
		1	443-0471	225		010	
12	IMPELLER KEY (S) (L)	1	472-0201	087		087	
		1	472-0247	087		087	
14	IMPELLER RING (OPTIONAL) 1-1/4 x 1-1/2 x 7 1-1/2 x 2 x 7 2 x 2-1/2 x 7A 2 x 2-1/2 x 7B 2-1/2 x 3 x 7A 2-1/2 x 3 x 7B 4 x 4 x 7A 4 x 4 x 7B						
		1	676-1145	208		010	
		1	676-1146	208		010	
		1	676-1133	208		010	
		1	676-1133	208		010	
		1	676-1133	208		010	
		1	676-1133	208		010	
		1	676-1140	208		010	
1	676-1140	208		010			
15	IMPELLER RING (OPTIONAL) 2 x 2-1/2 x 7A 2 x 2-1/2 x 7B 2-1/2 x 3 x 7A 2-1/2 x 3 x 7B 4 x 4 x 7A 4 x 4 x 7B						
		1	676-1133	208		010	
		1	676-1133	208		010	
		1	676-1133	208		010	
		1	676-1133	208		010	
		1	676-1133	208		010	
16	RING (NOT REQUIRED)						
25	SLEEVE (S) (L)	1	756-0077	208		104	
		1	756-0078	208		104	
27	SEAL (S) (L)	1	712-0907	753		753	
		1	712-0910	753		753	
32	CAPSCREW MTR. FR. 143JM – 184JM 213JM – 256JM						
		4	168-0386	082		082	
		4	168-0490	082		082	
33	U DRIVE SCREW	2	708-0013	365		365	
34	NAMEPLATE	1	532-0045	114		114	
35	BRACKET (341A)						
		1	116-0192	010		010	
		1	116-0194	010		010	
		1	116-0197	010		010	
	1	116-0476	010		010		
	BRACKET (342A)						
		1	116-0192	010		010	
		1	116-0194	010		010	
		1	116-0197	010		010	
		1	116-0192	010		010	
1		116-0197	010		010		

\*MACHINED FOR OPTIONAL RING NUMBERS 14 & 15

**AURORA® 340A SERIES**  
**MODELS 341A - 342A- 344A**  
**1-1/4 x 1-1/2 x 7 – 4 x 4 x 7B**

**PARTS LIST**

PC. NO.	DESCRIPTION	QTY	PART NO.	MATERIAL		
				B.F.		A.I.
35	BRACKET (342A)					
	284JM - 326JM	1	116-0476	010		010
	BRACKET (344A)					
	POWER FRAME #1	1	116-0192	010		010
	POWER FRAME #2	1	116-0197	010		010
39	CAPSCREW (341A)					
	143JM – 184JM	3	168-0488	082		082
	213JM – 256JM	NOT REQUIRED				
	CAPSCREW (342A)					
	1-1/4 x 1-1/2 x 7	4	168-0490	082		082
	1-1/2 x 2 x 7	4	168-0560	082		082
	2 x 2-1/2 x 7A & B	4	168-0562	082		082
	2-1/2 x 3 X 7A & B	4	168-0562	082		082
	4 x 4 x 7A & B	4	168-0564	082		082
	CAPSCREW (344A)					
	POWER FRAME #1	3	168-0488	082		082
	POWER FRAME #2	2	168-0490	082		082
	40	WASHER (341A)				
143JM – 184JM		3	908-0114	080		080
213JM – 256JM		NOT REQUIRED				
WASHER (342A)		NOT REQUIRED				
WASHER (344A)						
POWER FRAME #1		3	908-0114	080		080
POWER FRAME #2		2	908-0114	080		080
41	SUPPORT (341A)					
	143JM – 184JM	1	820-0184	010		010
	213JM – 256JM	NOT REQUIRED				
	SUPPORT (344A)					
	POWER FRAME #1	1	820-1441	087		087
	POWER FRAME #2	1	820-0186	010		010
42	DRIVE KEY (344A)					
	POWER FRAME #1	1	472-0206	087		087
	POWER FRAME #2	1	472-0247	087		087
43	GREASE FITTING					
	POWER FRAME #1 & #2	1	508-0005	651		651
44	VENT TUBE					
	POWER FRAME #1 & #2	1	864-0051	656		656
46	PROTECTOR					
	POWER FRAME #1 & #2	1	624-0010	503		503
47	SLINGER					
	POWER FRAME #1	1	764-1015	478		478
	POWER FRAME #2	1	764-1021	478		478
47A	SLINGER					
	POWER FRAME #1	1	764-1015	478		478
	POWER FRAME #2	1	764-1021	478		478
48	CAPSCREW					
	POWER FRAME #1	4	168-0388	082		082
	POWER FRAME #2	4	168-0492	082		082
49	BEARING CAP					
	POWER FRAME #1	1	164-0470	010		010
	POWER FRAME #2	1	164-0471	010		010

PC. NO.	DESCRIPTION	QTY	PART NO.	MATERIAL		
				B.F.		A.I.
50	O-RING					
	POWER FRAME #1	1	364-0423	457		457
	POWER FRAME #2	1	364-0432	457		457
51	SEAL, GREASE LUBE					
	POWER FRAME #1	1	712-0231	653		653
	POWER FRAME #2	1	712-0233	653		653
	SEAL, OIL LUBE					
	POWER FRAME #1	1	712-0016	653		653
	POWER FRAME #2	1	712-0054	653		653
51A	SEAL, GREASE LUBE					
	POWER FRAME #1	1	712-0231	653		653
	POWER FRAME #2	1	712-0233	653		653
	SEAL, OIL LUBE					
	POWER FRAME #1	1	712-0016	653		653
	POWER FRAME #2	1	712-0054	653		653
52	RET. RING					
	POWER FRAME #1	1	676-0929	088		088
	POWER FRAME #1	1	676-0938	088		088
53	O.B. BEARING					
	POWER FRAME #1					
	STANDARD OPEN	1	068-2206	647		647
	SEALED PERM LUBE	1	068-2219	647		647
	POWER FRAME #2					
	STANDARD OPEN	1	068-2308	647		647
	SEALED PERM LUBE	1	068-2220	647		647
54	I.B. BEARING					
	POWER FRAME #1					
	STANDARD OPEN	1	068-1907	647		647
	SEALED PERM LUBE	1	068-0114	647		647
	POWER FRAME #2					
	STANDARD OPEN	1	068-0159	647		647
	SEALED PERM LUBE	1	068-2018	647		647
55	SHAFT					
	POWER FRAME #1	1	728-0121	063		063
	POWER FRAME #2	1	728-0122	063		063
56	PROTECTOR					
	POWER FRAME #1 & #2	2	624-0010	503		503
57	FRAME					
	GREASE					
	POWER FRAME #1	1	356-0201	010		010
	OIL LUBE					
	POWER FRAME #1	1	356-0231	010		010
	OIL LUBE					
	POWER FRAME #2	1	356-0232	010		010
	GREASE					
	POWER FRAME #2	1	356-0202	010		010
58	GREASE FITTING					
	POWER FRAME #1 & #2	1	508-0001	651		651



**AURORA® 340A SERIES**  
**MODELS 341A - 342A- 344A**  
**1-1/4 x 1-1/2 x 7 – 4 x 4 x 7B**

SECTION 340P PAGE 9  
 DATED MARCH 2014  
 SUPERSEDES 340P PAGE 9  
 DATED AUGUST 2013

**PARTS LIST**

PC. NO.	DESCRIPTION	QTY	PART NO.	MATERIAL		
				B.F.		A.I.
59	PIPE PLUG POWER FRAME #1 & #2	2	600-0001	087		087
60	OILER POWER FRAME #1 & #2	1	552-0029	652		652
61	PIN	INCLUDED WITH NO. 25				
62	CAPSCREW POWER FRAME #1 POWER FRAME #2	1 2	168-0490 168-0490	080 080		080 080
63	WASHER POWER FRAME #1 POWER FRAME #2	1 1	908-0114 908-0114	080 080		080 080
64	SUPPORT POWER FRAME #1 POWER FRAME #2	1 1	820-0187 820-0188	010 010		010 010
72	GASKET 1-1/4 x 1-1/2 x 7 1-1/2 x 2 x 7 2 x 2-1/2 x 7A & 7B 2-1/2 x 3 x 7A & 7B 4 x 4 x 7A & 7B	1 1 1 1 1	364-0602 364-0603 364-0604 364-0605 364-0607	603 603 603 603 603		603 603 603 603 603
73	BASE 1-1/4 x 1-1/2 x 7 1-1/2 x 2 x 7 2 x 2-1/2 x 7A & B 2-1/2 x 3 x 7A & B 4 x 4 x 7A & B	1 1 1 1 1	816-1102 816-1103 816-1104 816-1105 816-1106	010 010 010 010 010		010 010 010 010 010
74	PIPE PLUG	1	600-0002	087		087
75	PIPE PLUG 1-1/4 x 1-1/2 x 7 1-1/2 x 2 x 7 2 x 2-1/2 x 7A & 7B 2-1/2 x 3 x 7A & 7B 4 x 4 x 7A & 7B	1 1 1 1 1	600-0002 600-0003 600-0003 600-0004 600-0004	087 087 087 028 028		087 087 087 028 028
	(NOT SHOWN)					
	SEAL KIT (S)	1	476-0250	644		
	(INCLUDES PIECE NO'S 8, 9, 9A, 9B, 9C, 10, 12, 25, 27)					
	SEAL KIT (L)	1	476-0253	644		

**AURORA® 340A SERIES**  
**MODELS 341A - 342A - 344A**  
**1-1/4 x 1-1/2 x 9B – 6 x 6 x 9**

**PARTS LIST**

PC. NO.	DESCRIPTION	QTY	PART NO.	MATERIAL		
				B.F.	A.I.	
1	COMPRESSION ELBOW	1	868-3660	190		087
2	COMPRESSION CONNECTOR	1	868-3359	190		087
3	TUBING	1	872-0124	175		087
4	PIPE PLUG	3	600-0002	087		087
5	CAPSCREW	8	168-0487	082		082
6	CASING					
	1-1/4 x 1-1/2 x 9B	1	180-2148	010		010
	1-1/2 x 2 x 9A	1	180-2149	010		010
	1-1/2 x 2 x 9B	1	180-2149	010		010
	1-1/2 x 2 x 9C	1	180-2151	010		010
	2 x 2-1/2 x 9	1	180-2152	010		010
	2-1/2 x 3 x 9	1	180-2153	010		010
	3 x 4 x 9A	1	180-2351	010		010
	3 x 4 x 9B	1	180-2351	010		010
	4 x 5 x 9A	1	180-2156	010		010
	4 x 5 x 9B	1	180-2157	010		010
	6 x 6 x 9	1	180-2159	010		010
	VERTICAL					
	1-1/4 x 1-1/2 x 9B	1	180-2198	010		010
	1-1/2 x 2 x 9A	1	180-2199	010		010
	1-1/2 x 2 x 9B	1	180-2199	010		010
	1-1/2 x 2 x 9C	1	180-2200	010		010
7	CASE RING					
	1-1/4 x 1-1/2 x 9B	1	676-1150	208		010
	1-1/2 x 2 x 9A	1	676-1151	208		010
	1-1/2 x 2 x 9B	1	676-1151	208		010
	1-1/2 x 2 x 9C	1	676-1151	208		010
	2 x 2-1/2 x 9	1	676-1152	208		010
	2-1/2 x 3 x 9	1	676-1152	208		010
	3 x 4 x 9A	1	676-1154	208		010
	3 x 4 x 9B	1	676-1154	208		010
	4 x 5 x 9A	1	676-1154	208		010
	4 x 5 x 9B	1	676-1155	208		010
	6 x 6 x 9	1	676-1155	208		010
8	GASKET	1	364-1015	603		603
9	CAPSCREW	(S)	1 168-0382	113		113
		(L)	1 168-0490	113		113
9A	WASHER	(S)	1 908-0603	087		087
		(L)	1 908-0604	087		087
9B	GASKET	(S)	1 364-2034	603		603
		(L)	1 364-2035	603		603
9C	CAPSCREW	(S)	1 908-1290	999		999
	SEAL	(L)	1 908-1292	999		999
10	O-RING	(S)	1 364-0409	457		457
		(L)	1 364-0414	457		457
11	IMPELLER	(S)				
	1-1/4 x 1-1/2 x 9B	1	443-0431	225		010
	1-1/2 x 2 x 9A	1	443-0437	225		010
	1-1/2 x 2 x 9B	1	443-0435	225		010
	1-1/2 x 2 x 9C	1	443-0437	225		010
	2 x 2-1/2 x 9	1	443-0441	225		010
	2-1/2 x 3 x 9	1	443-0445	225		010

PC. NO.	DESCRIPTION	QTY	PART NO.	MATERIAL		
				B.F.	A.I.	
11	IMPELLER (S)					
	3 x 4 x 9A	1	443-1766	225		010
	3 x 4 x 9B	1	443-1762	225		010
	4 x 5 x 9A	1	443-1777	225		010
	4 x 5 x 9B	1	443-0457	225		010
	6 x 6 x 9	1	443-0465	225		010
11	IMPELLER (L)					
	1-1/2 x 2 x 9C	1	443-0439	225		010
	2 x 2-1/2 x 9	1	443-0443	225		010
	2-1/2 x 3 x 9	1	443-0447	225		010
	3 x 4 x 9A	1	443-1768	225		010
	3 x 4 x 9B	1	443-1764	225		010
	4 x 5 x 9A	1	443-1752	225		010
	4 x 5 x 9B	1	443-0459	225		010
	6 x 6 x 9	1	443-0467	225		010
11A	IMPELLER (S)*					
	1-1/4 x 1-1/2 x 9B	1	443-0432	225		010
	1-1/2 x 2 x 9A	1	443-0438	225		010
	1-1/2 x 2 x 9B	1	443-0436	225		010
	1-1/2 x 2 x 9C	1	443-0438	225		010
	2 x 2-1/2 x 9	1	443-0442	225		010
	2-1/2 x 3 x 9	1	443-0446	225		010
	3 x 4 x 9A	1	443-1767	225		010
	3 x 4 x 9B	1	443-1763	225		010
	4 x 5 x 9A	1	443-1778	225		010
	4 x 5 x 9B	1	443-0458	225		010
	6 x 6 x 9	1	443-0466	225		010
11A	IMPELLER (L)*					
	1-1/2 x 2 x 9C	1	443-0440	225		010
	2 x 2-1/2 x 9	1	443-0444	225		010
	2-1/2 x 3 x 9	1	443-0448	225		010
	3 x 4 x 9A	1	443-1769	225		010
	3 x 4 x 9B	1	443-1765	225		010
	4 x 5 x 9A	1	443-1753	225		010
	4 x 5 x 9B	1	443-0460	225		010
	6 x 6 x 9	1	443-0468	225		010
12	IMPELLER KEY (S)	1	472-0201	087		087
		(L)	1 472-0247	087		087
14	IMPELLER RING (OPTIONAL)					
	1-1/4 x 1-1/2 x 9B	1	676-1145	208		010
	1-1/2 x 2 x 9	1	676-1146	208		010
	2 x 2-1/2 x 9	1	676-1133	208		010
	2-1/2 x 3 x 9	1	676-1133	208		010
	3 x 4 x 9A & B	1	676-1140	208		010
	4 x 5 x 9A	1	676-1140	208		010
	4 x 5 x 9B	1	676-1141	208		010
	6 x 6 x 9	1	676-1141	208		010

\*MACHINED FOR OPTIONAL RING NUMBERS 14 & 15

**AURORA® 340A SERIES**  
**MODELS 341A - 342A - 344A**  
**1-1/4 x 1-1/2 x 9B – 6 x 6 x 9**

SECTION 340P PAGE 11  
 DATED MARCH 2014  
 SUPERSEDES 340P PAGE 11  
 DATED AUGUST 2013

**PARTS LIST**

PC. NO.	DESCRIPTION	QTY	PART NO.	MATERIAL		
				B.F.		A.I.
15	IMPELLER RING (OPTIONAL)					
	2 x 2-1/2 x 9	1	676-1133	208		010
	2-1/2 x 3 x 9	1	676-1133	208		010
	3 x 4 x 9A	1	676-1156	208		010
	3 x 4 x 9B	1	676-1156	208		010
	4 x 5 x 9A	1	676-1156	208		010
	4 x 5 x 9B	1	676-1156	208		010
	6 x 6 x 9	1	676-1156	208		010
16	RING					
	2 x 2-1/2 x 9	1	676-0003	010		010
	2-1/2 x 3 x 9	1	676-0003	010		010
25	SLEEVE (S)	1	756-0077	208		104
	(L)	1	756-0078	208		104
27	SEAL (S)	1	712-0907	753		753
	(L)	1	712-0910	753		753
32	CAPSCREW MTR. FR.					
	143JM – 184JM	4	168-0386	082		082
	213JM – 256JM	4	168-0490	082		082
33	U DRIVE SCREW	2	708-0013	365		365
34	NAMEPLATE	1	532-0045	114		114
35	BRACKET (341A)					
	143JM – 184JM	1	116-0193	010		010
	213JM – 215JM	1	116-0195	010		010
	254JM – 256JM	1	116-0198	010		010
	284JM – 326JM	1	116-0477	010		010
	BRACKET (342A)					
	143JM – 184JM	1	116-0193	010		010
	213JM – 215JM	1	116-0195	010		010
	254JM – 256JM	1	116-0198	010		010
	284JM – 326JM	1	116-0477	010		010
	BRACKET (344A)					
	POWER FRAME #1	1	116-0193	010		010
	POWER FRAME #2 & #3	1	116-0198	010		010
	39	CAPSCREW (341A)				
143JM – 184JM		3	168-0488	082		082
213JM – 256JM		NOT REQUIRED				
CAPSCREW (342A)						
1-1/4 x 1-1/2 x 9B		4	168-0490	082		082
1-1/2 x 2 x 9		4	168-0560	082		082
2 x 2-1/2 x 9		4	168-0562	082		082
2-1/2 x 3 x 9		4	168-0562	082		082
3 x 4 x 9		4	168-0564	082		082
4 x 5 x 9A & B		4	168-0564	082		082
6 x 6 x 9		4	168-0634	082		082
CAPSCREW (344A)						
POWER FRAME #1		3	168-0488	082		082
POWER FRAME #2 & #3		2	168-0490	082		082

PC. NO.	DESCRIPTION	QTY	PART NO.	MATERIAL		
				B.F.		A.I.
40	WASHER (341A)					
	143JM – 184JM	3	908-0114	080		080
	213JM – 256JM	NOT REQUIRED				
	WASHER (342A)	NOT REQUIRED				
	WASHER (344A)					
	POWER FRAME #1	3	908-0114	080		080
	POWER FRAME #2 & #3	2	908-0114	080		080
41	SUPPORT (341A)					
	143JM – 184JM	1	820-0184	010		010
	213JM – 256JM	NOT REQUIRED				
	SUPPORT (344A)					
	POWER FRAME #1	1	820-1441	087		087
	POWER FRAME #2 & #3	1	820-0186	010		010
42	DRIVE KEY (344A)					
	POWER FRAME #1	1	472-0206	087		087
	POWER FRAME #2	1	472-0247	087		087
43	GREASE FITTING					
	POWER FRAME #1, #2 & #3	1	508-0005	651		651
44	VENT TUBE	1	864-0051	656		656
46	PROTECTOR	2	624-0010	503		503
47	SLINGER					
	POWER FRAME #1	1	764-1015	478		478
	POWER FRAME #2 & #3	1	764-1021	478		478
47A	SLINGER					
	POWER FRAME #1	1	764-1015	478		478
	POWER FRAME #2	1	764-1021	478		478
	POWER FRAME #3	1	764-1026	478		478
48	CAPSCREW					
	POWER FRAME #1	4	168-0388	082		082
	POWER FRAME #2 & #3	4	168-0492	082		082
49	BEARING CAP					
	POWER FRAME #1	1	164-0470	010		010
	POWER FRAME #2	1	164-0471	010		010
	POWER FRAME #3	1	164-0472	010		010
50	O-RING					
	POWER FRAME #1	1	364-0423	457		457
	POWER FRAME #2	1	364-0432	457		457
	POWER FRAME #3	1	364-0438	457		457
51	SEAL					
	POWER FRAME #1	1	712-0231	653		653
	POWER FRAME #2 & #3	1	712-0233	653		653
	OIL LUBE					
	POWER FRAME #1	1	712-0016	653		653
	POWER FRAME #2 & #3	1	712-0054	653		653

**AURORA® 340A SERIES**  
**MODELS 341A - 342A - 344A**  
**1-1/4 x 1-1/2 x 9B – 6 x 6 x 9**

**PARTS LIST**

PC. NO.	DESCRIPTION	QTY	PART NO.	MATERIAL		
				B.F.	A.I.	
51A	SEAL					
	POWER FRAME #1	1	712-0231	653		653
	POWER FRAME #2	1	712-0233	653		653
	POWER FRAME #3	1	712-0234	653		653
	OIL LUBE					
	POWER FRAME #1	1	712-0016	653		653
	POWER FRAME #2	1	712-0054	653		653
	POWER FRAME #3	1	712-0056	653		653
	52	RET. RING				
POWER FRAME #1		1	676-0929	088		088
POWER FRAME #2		1	676-0938	088		088
POWER FRAME #3		1	676-0944	088		088
53	O.B. BEARING					
	POWER FRAME #1					
	STANDARD OPEN	1	068-2206	647		647
	SEALED PERM LUBE	1	068-2219	647		647
	POWER FRAME #2					
	STANDARD OPEN	1	068-2308	647		647
	SEALED PERM LUBE	1	068-2220	647		647
	POWER FRAME #3					
	STANDARD OPEN	1	068-2310	647		647
SEALED PERM LUBE	1	068-2221	647		647	
54	I.B. BEARING					
	POWER FRAME #1					
	STANDARD OPEN	1	068-1907	647		647
	SEALED PERM LUBE	1	068-0114	647		647
	POWER FRAME #2					
	STANDARD OPEN	1	068-0159	647		647
	SEALED PERM LUBE	1	068-2018	647		647
	POWER FRAME #3					
	STANDARD OPEN	1	068-0161	647		647
SEALED PERM LUBE	1	068-2022	647		647	
55	SHAFT					
	POWER FRAME #1	1	728-0121	063		063
	POWER FRAME #2	1	728-0122	063		063
56	PROTECTOR					
	POWER FRAME #1, #2 & #3	2	624-0010	503		503
57	FRAME					
	OIL LUBE					
	POWER FRAME #1	1	356-0231	010		010
	POWER FRAME #2	1	356-0232	010		010
	POWER FRAME #3	1	356-0233	010		010
	GREASE					
	POWER FRAME #1	1	356-0201	010		010
	POWER FRAME #2	1	356-0202	010		010
	POWER FRAME #3	1	356-0203	010		010

PC. NO.	DESCRIPTION	QTY	PART NO.	MATERIAL		
				B.F.	A.I.	
58	GREASE FITTING					
	POWER FRAME #1, #2 & #3	1	508-0001	651		651
59	PIPE PLUG					
	POWER FRAME #1, #2 & #3	2	600-0001	087		087
60	OILER					
	POWER FRAME #1, #2 & #3	1	552-0029	652		652
61	PIN		INCLUDED WITH NO. 25			
62	CAPSCREW					
	POWER FRAME #1	1	168-0490	082		082
	POWER FRAME #2 & #3	2	168-0490	082		082
63	WASHER					
	POWER FRAME #1	1	908-0114	080		080
	POWER FRAME #2 & #3	1	908-0114	080		080
64	SUPPORT					
	POWER FRAME #1	1	820-0121	010		010
	POWER FRAME #2 & #3	1	820-0189	010		010
72	GASKET					
	1-1/4 x 1-1/2 x 9B	1	364-0602	603		603
	1-1/2 x 2 x 9A, B & C	1	364-0603	603		603
	2 x 2-1/2 x 9	1	364-0604	603		603
	2-1/2 x 3 x 9	1	364-0605	603		603
	3 x 4 x 9A & B	1	364-0607	603		603
	4 x 5 x 9A & B	1	364-0608	603		603
	6 x 6 x 9	1	364-0609	603		603
73	BASE					
	1-1/4 x 1-1/2 x 9B	1	816-1102	010		010
	1-1/2 x 2 x 9A, B & C	1	816-1103	010		010
	2 x 2-1/2 x 9	1	816-1104	010		010
	2-1/2 x 3 x 9	1	816-1105	010		010
	3 x 4 x 9A & B	1	816-1106	010		010
	4 x 5 x 9A & B	1	816-1107	010		010
6 x 6 x 9	1	816-1108	010		010	
74	PIPE PLUG	1	600-0002	087		087
75	PIPE PLUG					
	1-1/4 x 1-1/2 x 9B	1	600-0002	087		087
	1-1/2 x 2 x 9A, B & C	1	600-0003	087		087
	2 x 2-1/2 x 9	1	600-0003	087		087
	2-1/2 x 3 x 9	1	600-0004	028		028
	3 x 4 x 9A & B	1	600-0004	028		028
	4 x 5 x 9A & B	1	600-0022	028		028
	6 x 6 x 9	1	600-0022	028		028
(NOT SHOWN)						
SEAL KIT (S)	1	476-0250	644			
(INCLUDES PIECE NO'S 8, 9, 9A, 9B, 9C, 10, 12, 25, 27)						
SEAL KIT (L)	1	476-0253	644			

**AURORA® 340A SERIES**  
**MODELS 341A - 342A - 344A**  
**1-1/2 x 2 x 11 – 6 x 6 x 11A**

SECTION 340P PAGE 13  
 DATED MARCH 2014  
 SUPERSEDES 340P PAGE 13  
 DATED AUGUST 2013

**PARTS LIST**

PC. NO.	DESCRIPTION	QTY	PART NO.	MATERIAL		
				B.F.		A.I.
1	COMPRESSION ELBOW	1	868-3660	190		087
2	COMPRESSION CONNECTOR	1	868-3359	190		087
3	TUBING	1	872-0124	175		087
4	PIPE PLUG	3	600-0002	087		087
5	CAPSCREW	8	168-0490	082		082
6	CASING					
	1-1/2 x 2 x 11	1	180-2353	010		010
	2 x 3 x 11	1	180-2354	010		010
	3 x 4 x 11	1	180-2371	010		010
	4 x 5 x 11	1	180-2356	010		010
	5 x 6 x 11	1	180-2357	010		010
	6 x 6 x 11	1	180-2172	010		010
	6 x 6 x 11A	1	180-2363	010		010
	VERTICAL					
	1-1/2 x 2 x 11	1	180-2457	010		010
7	CASE RING					
	1-1/2 x 2 x 11	1	676-1151	208		010
	2 x 3 x 11	1	676-1152	208		010
	3 x 4 x 11	1	676-1154	208		010
	4 x 5 x 11	1	676-1155	208		010
	5 x 6 x 11	1	676-1684	208		010
	6 x 6 x 11	1	676-1684	208		010
6 x 6 x 11A	1	676-1684	208		010	
8	GASKET	1	364-2109	603		603
	6 x 6 x 11 & 11A ONLY	1	364-1016	603		603
9	CAPSCREW (S)	1	168-0382	113		113
	(L)	1	168-0490	113		113
9A	WASHER (S)	1	908-0603	087		087
	(L)	1	908-0604	087		087
9B	GASKET (S)	1	364-2034	603		603
	(L)	1	364-2035	603		603
9C	CAPSCREW SEAL (S)	1	908-1290	999		999
	(L)	1	908-1292	999		999
10	O-RING (S)	1	364-0409	457		457
	(L)	1	364-0414	457		457
11	IMPELLER (S)					
	1-1/2 x 2 x 11	1	443-2511	225		010
	2 x 3 x 11	1	443-2387	225		010
	3 x 4 x 11	1	443-2388	225		010
	4 x 5 x 11	1	443-2389	225		010
	5 x 6 x 11	1	443-2390	225		010
	6 x 6 x 11	1	443-2390	225		010
	6 x 6 x 11A	1	443-2390	225		010

PC. NO.	DESCRIPTION	QTY	PART NO.	MATERIAL		
				B.F.		A.I.
11	IMPELLER (L)					
	1-1/2 x 2 x 11	1	443-2513	225		010
	2 x 3 x 11	1	443-2399	225		010
	3 x 4 x 11	1	443-2400	225		010
	4 x 5 x 11	1	443-2401	225		010
	5 x 6 x 11	1	443-2402	225		010
	6 x 6 x 11	1	443-2402	225		010
6 x 6 x 11A	1	443-2402	225		010	
11A	IMPELLER (S)*					
	1-1/2 x 2 x 11	1	443-2512	225		010
	2 x 3 x 11	1	443-2423	225		010
	3 x 4 x 11	1	443-2424	225		010
	4 x 5 x 11	1	443-2425	225		010
	5 x 11	1	443-2426	225		010
	6 x 11	1	443-2426	225		010
6 x 11A	1	443-2426	225		010	
11A	IMPELLER (L)*					
	1-1/2 x 2 x 11	1	443-2514	225		010
	2 x 3 x 11	1	443-2427	225		010
	3 x 4 x 11	1	443-2428	225		010
	4 x 5 x 11	1	443-2429	225		010
	5 x 11	1	443-2430	225		010
	6 x 11	1	443-2430	225		010
6 x 11A	1	443-2430	225		010	
12	IMPELLER KEY (S)	1	472-0201	087		087
	IMPELLER KEY (L)	1	472-0247	087		087
14	IMPELLER RING (OPTIONAL)					
	1-1/2 x 2 x 11	1	676-1146	208		010
	2 x 3 x 11	1	676-1133	208		010
	3 x 4 x 11	1	676-1140	208		010
	4 x 5 x 11	1	676-1141	208		010
	5 x 6 x 11	1	676-1143	208		010
	6 x 6 x 11	1	676-1143	208		010
6 x 6 x 11A	1	676-1143	208		010	
15	IMPELLER RING (OPTIONAL)					
	2 x 3 x 11	1	676-1133	208		010
	3 x 4 x 11	1	676-1156	208		010
	4 x 5 x 11	1	676-1156	208		010
	5 x 6 x 11	1	676-1156	208		010
	6 x 6 x 11	1	676-1156	208		010
6 x 6 x 11A	1	676-1156	208		010	
16	RING 2 x 3 x 11	1	676-0003	010		010

\*MACHINED FOR OPTIONAL RING NUMBERS 14 & 15

**AURORA® 340A SERIES**  
**MODELS 341A - 342A - 344A**  
**1-1/2 x 2 x 11 – 6 x 6 x 11A**

**PARTS LIST**

PC. NO.	DESCRIPTION	QTY	PART NO.	MATERIAL			
				B.F.	A.I.		
25	SLEEVE	(S)	1 756-0077	208		104	
		(L)	1 756-0078	208		104	
27	SEAL	(S)	1 712-0907	753		753	
		(L)	1 712-0910	753		753	
32	CAPSCREW MTR. FR. 213JM – 215JM 254JM – 256JM 284JM – 326JM		4 168-0490	082		082	
			4 168-0490	082		082	
			4 168-0562	082		082	
			4 168-0562	082		082	
33	U DRIVE SCREW		2 708-0013	365		365	
34	NAMEPLATE		1 532-0045	114		114	
35	BRACKET (341A) EXCEPT 6 x 6 x 11 AND 6 x 6 x 11A						
	213JM – 215JM		1 116-0465	010		010	
	254JM – 256JM		1 116-0466	010		010	
	284JM – 326JM		1 116-0467	010		010	
	BRACKET (342A) EXCEPT 6 x 6 x 11 AND 6 x 6 x 11A						
	213JM – 215JM		1 116-0465	010		010	
	254JM – 256JM		1 116-0466	010		010	
	284JM – 326JM		1 116-0467	010		010	
	BRACKET (344A) EXCEPT 6 x 6 x 11 AND 6 x 6 x 11A						
	POWER FRAME #2 & #3		1 116-0466	010		010	
	35	BRACKET (341A) 6 x 6 x 11 AND 6 x 6 x 11A ONLY					
		213JM – 215JM		1 116-0196	010		010
254JM – 256JM			1 116-0199	010		010	
BRACKET (342A) 6 x 6 x 11 AND 6 x 6 x 11A ONLY							
213JM – 215JM			1 116-0196	010		010	
254JM – 256JM			1 116-0199	010		010	
284JM – 326JM			1 116-0088	010		010	
BRACKET (344A) 6 x 6 x 11 AND 6 x 6 x 11A ONLY							
POWER FRAME #2 & #3			1 116-0199	010		010	
39		CAPSCREW (341A)					
		CAPSCREW (342A)					
		1-1/2 x 2 x 11		4 168-0560	082		082
	2 x 3 x 11		4 168-0562	082		082	
	3 x 4 x 11		8 168-0564	082		082	
	4 x 5 x 11		8 168-0634	082		082	
	5 x 6 x 11		8 168-0634	082		082	
	6 x 6 x 11		8 168-0634	082		082	
	6 x 6 x 11A		8 168-0634	082		082	
	CAPSCREW (344A)						
	POWER FRAME #2 & #3		2 168-0490	082		082	
40	WASHER (341A) NOT REQUIRED						
	WASHER (342A) NOT REQUIRED						
	WASHER (344A)						
	POWER FRAME #2 & #3		2 908-0114	080		080	
41	SUPPORT (341) NOT REQUIRED						
	SUPPORT (342) NOT REQUIRED						
	SUPPORT (344)						
	POWER FRAME #2 & #3		1 820-0186	010		010	
42	DRIVE KEY (344)						
	POWER FRAME #2 & #3		1 472-0247	087		087	

PC. NO.	DESCRIPTION	QTY	PART NO.	MATERIAL		
				B.F.	A.I.	
43	GREASE FITTING POWER FRAME #2 & #3					
		1	508-0005	651		651
47	SLINGER POWER FRAME #2 & #3					
		1	764-1021	478		478
47A	SLINGER POWER FRAME #2 POWER FRAME #3					
		1	764-1021	478		478
		1	764-1026	478		478
48	CAPSCREW POWER FRAME #2 & #3					
		4	168-0492	082		082
49	BEARING CAP POWER FRAME #2 POWER FRAME #3					
		1	164-0471	010		010
		1	164-0472	010		010
50	O-RING POWER FRAME #2 POWER FRAME #3					
		1	364-0432	457		457
		1	364-0438	457		457
51	SEAL POWER FRAME #2 & #3 OIL LUBE POWER FRAME #2 & #3					
		1	712-0233	653		653
		1	712-0054	653		653
51A	SEAL POWER FRAME #2 POWER FRAME #3 OIL LUBE POWER FRAME #2 POWER FRAME #3					
		1	712-0233	653		653
		1	712-0234	653		653
		1	712-0054	653		653
		1	712-0056	653		653
52	RETAINING RING POWER FRAME #2 POWER FRAME #3					
		1	676-0938	088		088
		1	676-0944	088		088
53	O.B. BEARING POWER FRAME #2 STANDARD OPEN SEALED PERM LUBE POWER FRAME #3 STANDARD OPEN SEALED PERM LUBE					
		1	068-2308	647		647
		1	068-2220	647		647
		1	068-2310	647		647
		1	068-2221	647		647
54	I.B. BEARING POWER FRAME #2 STANDARD OPEN SEALED PERM LUBE POWER FRAME #3 STANDARD OPEN SEALED PERM LUBE					
		1	068-0159	647		647
		1	068-2018	647		647
		1	068-0161	647		647
		1	068-2022	647		647
55	SHAFT POWER FRAME #2 POWER FRAME #3					
		1	728-0122	063		063
		1	728-0123	063		063



**AURORA® 340A SERIES**  
**MODELS 341A - 342A - 344A**  
**1-1/2 x 2 x 11 – 6 x 6 x 11A**

SECTION 340P PAGE 15  
 DATED MARCH 2014

SUPERSEDES 340P PAGE 15  
 DATED AUGUST 2013

**PARTS LIST**

PC. NO.	DESCRIPTION	QTY	PART NO.	MATERIAL	
				B.F.	A.I.
57	FRAME				
	OIL LUBE				
	POWER FRAME #2	1	356-0232	010	010
	GREASE				
	POWER FRAME #2	1	356-0202	010	010
	OIL LUBE				
	POWER FRAME #3	1	356-0233	010	010
	GREASE				
	POWER FRAME #3	1	356-0203	010	010
58	GREASE FITTING				
	POWER FRAME #2 & #3	1	508-0001	651	651
60	OILER				
	POWER FRAME #2 & #3	1	552-0029	652	652
61	PIN	INCLUDED WITH NO. 25			
62	CAPSCREW				
	POWER FRAME #2 & #3	2	168-0490	082	082
63	WASHER				
	POWER FRAME #2 & #3	1	908-0114	080	080
64	SUPPORT				
	POWER FRAME #2 & #3	1	820-0189	010	010
72	GASKET (342A)				
	1-1/2 x 3 x 11	1	364-0603	603	603
	2 x 3 x 11	1	364-0605	603	603
	3 x 4 x 11	1	364-0607	603	603
	4 x 5 x 11	1	364-0608	603	603
	5 x 6 x 11	1	364-0609	603	603
	6 x 6 x 11	1	364-0609	603	603
	6 x 6 x 11A	1	364-0609	603	603

PC. NO.	DESCRIPTION	QTY	PART NO.	MATERIAL	
				B.F.	A.I.
73	BASE (342A)				
	1-1/2 x 3 x 11	1	816-1103	010	010
	2 x 3 x 11	1	816-1105	010	010
	3 x 4 x 11	1	816-1106	010	010
	4 x 5 x 11	1	816-1107	010	010
	5 x 6 x 11	1	816-1108	010	010
	6 x 6 x 11	1	816-1108	010	010
	6 x 6 x 11A	1	816-1108	010	010
	74	PIPE PLUG (342A)	1	600-0002	087
75	PIPE PLUG (342A)				
	1-1/2 x 3 x 11	1	600-0003	087	087
	2 x 3 x 11	1	600-0004	087	087
	3 x 4 x 11	1	600-0004	087	087
	4 x 5 x 11	1	600-0005	087	087
	5 x 6 x 11	1	600-0005	028	028
	6 x 6 x 11	1	600-0005	028	028
	6 x 6 x 11A	1	600-0005	028	028
	(NOT SHOWN)				
	SEAL KIT (S)	1	476-0250	644	
	(INCLUDES PIECE NO'S 8, 9, 9A, 9B, 9C, 10, 12, 25, 27)				
	SEAL KIT (L)	1	476-0253	644	

**AURORA® 340A SERIES**  
**MODELS 341A- 342A- 344A**  
**1-1/2 x 2 x 12 – 6 x 6 x 12A**

**PARTS LIST**

PC. NO.	DESCRIPTION	QTY	PART NO.	MATERIAL		
				B.F.	A.I.	
1	COMPRESSION ELBOW	1	868-3660	190	087	
2	COMPRESSION CONNECTOR	1	868-3359	190	087	
3	TUBING	1	872-0124	175	087	
4	PIPE PLUG	3	600-0002	087	087	
5	CAPSCREW	8	168-0489	082	082	
6	CASING					
	1-1/2 x 2 x 12	1	180-2161	010	010	
	2 x 2-1/2 x 12	1	180-2163	010	010	
	2-1/2 x 3 x 12	1	180-2164	010	010	
	3 x 4 x 12	1	180-2166	010	010	
	4 x 5 x 12	1	180-2168	010	010	
	5 x 6 x 12	1	180-2170	010	010	
	6 x 6 x 12	1	180-2172	010	010	
	6 x 6 x 12A	1	180-2363	010	010	
7	VERTICAL					
	1-1/2 x 2 x 12	1	180-2201	010	010	
	CASE RING					
	1-1/2 x 2 x 12	1	676-1151	208	010	
	2 x 2-1/2 x 12	1	676-1152	208	010	
	2-1/2 x 3 x 12	1	676-1152	208	010	
	3 x 4 x 12	1	676-1154	208	010	
	4 x 5 x 12	1	676-1155	208	010	
	5 x 6 x 12	1	676-1684	208	010	
6 x 6 x 12	1	676-1684	208	010		
6 x 6 x 12A	1	676-1684	208	010		
8	GASKET	1	364-1016	603	603	
9	CAPSCREW (S)	1	168-0382	113	113	
		(L)	168-0490	113	113	
9A	WASHER (S)	1	908-0603	087	087	
		(L)	908-0604	087	087	
9B	GASKET (S)	1	364-2034	603	603	
		(L)	364-2035	603	603	
9C	CAPSCREW SEAL (S)	1	908-1290	999	999	
		(L)	908-1292	999	999	
10	O-RING (S)	1	364-0409	457	457	
		(L)	364-0414	457	457	
11	IMPELLER (S)	341& 342A ONLY				
		1-1/2 x 2 x 12	1	443-1734	225	010
		2 x 2-1/2 x 12	1	443-1735	225	010
		2-1/2 x 3 x 12	1	443-1736	225	010
		3 x 4 x 12	1	443-1737	225	010
11	IMPELLER (L)	1-1/2 x 2 x 12	1	443-1725	225	010
		2 x 2-1/2 x 12	1	443-1726	225	010
		2-1/2 x 3 x 12	1	443-1727	225	010
		3 x 4 x 12	1	443-1728	225	010
		4 x 5 x 12	1	443-1729	225	010

PC. NO.	DESCRIPTION	QTY	PART NO.	MATERIAL				
				B.F.	A.I.			
11	5 x 6 x 12	1	443-1730	225	010			
	6 x 6 x 12	1	443-1732	225	010			
	6 x 6 x 12A	1	443-1732	225	010			
11A	IMPELLER (S)*	341& 342A ONLY						
		1-1/2 x 2 x 12	1	443-1748	225	010		
		2 x 2-1/2 x 12	1	443-1753	225	010		
		2-1/2 x 3 x 12	1	443-1750	225	010		
		3 x 4 x 12	1	443-1751	225	010		
11A	IMPELLER (L)*	1-1/2 x 2 x 12	1	443-1739	225	010		
		2 x 2-1/2 x 12	1	443-1740	225	010		
		2-1/2 x 3 x 12	1	443-1741	225	010		
		3 x 4 x 12	1	443-1742	225	010		
		4 x 5 x 12	1	443-1743	225	010		
		5 x 6 x 12	1	443-1744	225	010		
		6 x 6 x 12	1	443-1746	225	010		
		6 x 6 x 12A	1	443-1746	225	010		
		12	IMPELLER KEY (S)	1	472-0201	087	087	
(L)	472-0247			087	087			
14	IMPELLER RING (OPTIONAL)	1-1/2 x 2 x 12	1	676-1146	208	010		
		2 x 2-1/2 x 12	1	676-1133	208	010		
		2-1/2 x 3 x 12	1	676-1133	208	010		
		3 x 4 x 12	1	676-1140	208	010		
		4 x 5 x 12	1	676-1141	208	010		
		5 x 6 x 12	1	676-1143	208	010		
		6 x 6 x 12	1	676-1143	208	010		
		6 x 6 x 12A	1	676-1143	208	010		
		15	IMPELLER RING (OPTIONAL)	2 x 2-1/2 x 12	1	676-1133	208	010
				2-1/2 x 3 x 12	1	676-1133	208	010
3 x 4 x 12	1			676-1156	208	010		
4 x 5 x 12	1			676-1156	208	010		
5 x 6 x 12	1			676-1156	208	010		
6 x 6 x 12	1			676-1156	208	010		
16	RING	2 x 2-1/2 x 12	1	676-0003	010	010		
		2-1/2 x 3 x 12	1	676-0003	010	010		
25	SLEEVE (S)	1	756-0077	208	104			
		(L)	756-0078	208	104			
27	SEAL (S)	1	712-0907	753	753			
		(L)	712-0910	753	753			

\*MACHINED FOR OPTIONAL RING NUMBERS 14 & 15



**AURORA® 340A SERIES**  
**MODELS 341A- 342A- 344A**  
**1-1/2 x 2 x 12 – 6 x 6 x 12A**

SECTION 340P PAGE 17  
 DATED MARCH 2014  
 SUPERSEDES 340P PAGE 17  
 DATED AUGUST 2013

**PARTS LIST**

PC. NO.	DESCRIPTION	QTY	PART NO.	MATERIAL			
				B.F.		A.I.	
32	CAPSCREW (341 & 342)						
	213JM – 215JM	4	168-0490	082		082	
	254JM – 256JM	4	168-0492	082		082	
	284JM – 326JM	4	168-0562	082		082	
	CAPSCREW (344)						
	POWER FRAME #2 & #3	4	168-0492	082		082	
33	U DRIVE SCREW	2	708-0013	365		365	
34	NAMEPLATE	1	532-0045	114		114	
35	BRACKET (341A)						
	213JM – 215JM	1	116-0196	010		010	
	254JM – 256JM	1	116-0199	010		010	
	BRACKET (342A)						
	213JM – 215JM	1	116-0196	010		010	
	254JM – 256JM	1	116-0199	010		010	
	284JM – 326JM	1	116-0088	010		010	
	BRACKET (344A)						
		POWER FRAME #2 & #3	1	116-0199	010		010
	39	CAPSCREW (341A)	NOT REQUIRED				
CAPSCREW (342A)							
1-1/2 x 2 x 12		4	168-0560	082		082	
2 x 2-1/2 x 12		4	168-0562	082		082	
2-1/2 x 3 x 12		4	168-0562	082		082	
3 x 4 x 12		4	168-0564	082		082	
4 x 5 x 12		4	168-0634	082		082	
5 x 6 x 12		4	168-0634	082		082	
6 x 6 x 12 & 12A		4	168-0634	082		082	
CAPSCREW (344A)							
	POWER FRAME #2 & #3	2	168-0490	082		082	
40	WASHER (341A)	NOT REQUIRED					
	WASHER (342A)	NOT REQUIRED					
	WASHER (344A)						
	POWER FRAME #2 & #3	2	908-0114	080		080	
41	SUPPORT (341A)						
	213JM – 215JM	NOT REQUIRED					
	254JM – 256JM	NOT REQUIRED					
	SUPPORT (344)						
	POWER FRAME #2 & #3	1	820-0186	010		010	
42	DRIVE KEY	1	472-0247	087		087	
43	GREASE FITTING	1	508-0005	657		651	
44	VENT TUBE	1	864-0051	656		656	
46	PROTECTOR	2	624-0010	503		503	
47	SLINGER						
	POWER FRAME #2 & #3	1	764-1021	478		478	
47A	SLINGER						
	POWER FRAME #2	1	764-1021	478		478	
	POWER FRAME #3	1	764-1026	478		478	

PC. NO.	DESCRIPTION	QTY	PART NO.	MATERIAL		
				B.F.		A.I.
48	CAPSCREW					
	POWER FRAME #2 & #3	4	168-0492	082		082
49	BEARING CAP					
	POWER FRAME #2	1	164-0471	010		010
	POWER FRAME #3	1	164-0472	010		010
50	O-RING					
	POWER FRAME #2	1	364-0432	457		457
	POWER FRAME #3	1	364-0438	457		457
51	SEAL					
	POWER FRAME #2 & #3	1	712-0233	653		653
	OIL LUBE					
	POWER FRAME #2 & #3	1	712-0054	653		653
51A	SEAL					
	POWER FRAME #2	1	712-0233	653		653
	POWER FRAME #3	1	712-0234	653		653
	OIL LUBE					
	POWER FRAME #2	1	712-0054	653		653
	POWER FRAME #3	1	712-0056	653		653
52	RETAINING RING					
	POWER FRAME #2	1	676-0938	088		088
	POWER FRAME #3	1	676-0944	088		088
53	O.B. BEARING					
	POWER FRAME #2					
	STANDARD OPEN	1	068-2308	647		647
	SEALED PERM LUBE	1	068-2220	647		647
	POWER FRAME #3					
	STANDARD OPEN	1	068-2310	647		647
SEALED PERM LUBE	1	068-2221	647		647	
54	I.B. BEARING					
	POWER FRAME #2					
	STANDARD OPEN	1	068-0159	647		647
	SEALED PERM LUBE	1	068-2018	647		647
	POWER FRAME #3					
	STANDARD OPEN	1	068-0161	647		647
	SEALED PERM LUBE	1	068-2022	647		647
55	SHAFT					
	POWER FRAME #2	1	728-0122	063		063
	POWER FRAME #3	1	728-0123	063		063
56	PROTECTOR	2	624-0010	503		503

**AURORA® 340A SERIES**  
**MODELS 341A- 342A- 344A**  
**1-1/2 x 2 x 12 – 6 x 6 x 12A**

**PARTS LIST**

PC. NO.	DESCRIPTION	QTY	PART NO.	MATERIAL		
				B.F.		A.I.
57	FRAME					
	OIL LUBE					
	POWER FRAME #2	1	356-0232	010		010
	POWER FRAME #3	1	356-0233	010		010
	GREASE					
	POWER FRAME #2	1	356-0202	010		010
	POWER FRAME #3	1	356-0203	010		010
58	GREASE FITTING	1	508-0001	651		651
59	PIPE PLUG					
	POWER FRAME #2 & #3	2	600-0001	087		087
60	OILER	1	522-0029	652		652
61	PIN	INCLUDED WITH NO. 25				
62	CAPSCREW					
	POWER FRAME #2 & #3	2	168-0490	082		082
63	WASHER	2	908-0114	080		080
64	SUPPORT					
	POWER FRAME #2 & #3	1	820-0189	010		010
72	GASKET					
	1-1/2 x 2 x 12	1	364-0603	603		603
	2 x 2-1/2 x 12	1	364-0604	603		603
	2-1/2 x 3 x 12	1	364-0605	603		603
	3 x 4 x 12	1	364-0607	603		603
	4 x 5 x 12	1	364-0609	603		603
	5 x 6 x 12	1	364-0609	603		603
	6 x 6 x 12 & 12A	1	364-0609	603		603

PC. NO.	DESCRIPTION	QTY	PART NO.	MATERIAL		
				B.F.		A.I.
73	BASE					
	1-1/2 x 2 x 12	1	816-1103	010		010
	2 x 2-1/2 x 12	1	816-1104	010		010
	2-1/2 x 3 x 12	1	816-1105	010		010
	3 x 4 x 12	1	816-1106	010		010
	4 x 5 x 12	1	816-1108	010		010
	5 x 6 x 12	1	816-1108	010		010
	6 x 6 x 12 & 12A	1	816-1108	010		010
74	PIPE PLUG	1	600-0002	087		087
75	PIPE PLUG					
	1-1/2 x 2 x 12	1	600-0003	087		087
	2 x 2-1/2 x 12	1	600-0003	087		087
	2-1/2 x 3 x 12	1	600-0004	087		087
	3 x 4 x 12	1	600-0004	028		028
	4 x 5 x 12	1	600-0005	028		028
	5 x 6 x 12	1	600-0005	028		028
	6 x 6 x 12 & 12A	1	600-0005	028		028
	(NOT SHOWN)					
	SEAL KIT (S)	1	476-0250	644		
	(INCLUDES PIECE NO'S 8, 9, 9A, 9B, 9C, 10, 12, 25, 27)					
	SEAL KIT (L)	1	476-0253	644		

**AURORA® 340A SERIES**  
**MODELS 341A- 342A- 344A**  
**6 x 6 x 12B – 6 x 8 x 15 – 8 x 10 x 15**

SECTION 340P PAGE 19  
 DATED MARCH 2014  
 SUPERSEDES 340P PAGE 19  
 DATED AUGUST 2013

**PARTS LIST**

PC. NO.	DESCRIPTION	QTY	PART NO.	MATERIAL		
				B.F.		A.I.
1	COMP. ELBOW	1	868-3660	190		087
2	COMP. CONN.	1	868-3359	190		087
3	TUBING	1	872-0124	175		087
4	PIPE PLUG	3	600-0002	087		087
5	CAPSCREW					
	6 x 6 x 12B	8	168-0489	082		082
	6 x 8 x 15	12	168-0636	082		082
6	CASING					
	6 x 6 x 12B	1	180-2516	010		010
	6 x 8 x 15	1	180-2366	010		010
7	CASE RING					
	6 x 6 x 12B	1	676-2100	208		010
	6 x 8 x 15	2	676-2036	222		010
8	GASKET					
	12"	1	364-1016	603		603
	15"	1	364-0557	457		457
9A	WASHER	1	908-1326	104		104
9B	GASKET	1	364-2046	603		603
10	O-RING	1	364-0419	457		457
11	IMPELLER					
	6 x 6 x 12B (L)	1	443-2664	225		010
	6 x 6 x 12B (XL)	1	443-3087	208		-
	6 x 8 x 15	1	443-3088	208		010
11A*	IMPELLER					
	6 x 6 x 12B (L)	1	443-2977	225		010
	6 x 6 x 12B (XL)	1	443-3087	208		-
	6 x 8 x 15	1	443-3089	208		010
12	IMPELLER KEY	1	472-0318	087		087
	IMPELLER RING, OPTIONAL					
	6 x 6 x 12B	1	676-2101	208		010
	6 x 8 x 15	1	676-1053	208		010
14	IMPELLER RING, OPTIONAL					
	6 x 6 x 12B	1	676-2101	208		010
	6 x 8 x 15	1	676-1053	208		010
15	IMPELLER RING, OPTIONAL					
	6 x 6 x 12B	1	676-2101	208		010
	6 x 8 x 15	1	676-1053	208		010
25	SHAFT SLEEVE	1	756-0692	208		104
27	MECHANICAL SEAL	1	712-1014	753		753
32	CAPSCREW					
	326 – 405 TCZ	4	168-0564	082		082
	444TCZ +	8	168-0566	082		082
33	WASHER	2	708-0013	365		365

PC. NO.	DESCRIPTION	QTY	PART NO.	MATERIAL		
				B.F.		A.I.
34	NAME PLATE	1	532-0045	114		114
35	BRACKET					
	12", 326 – 405 TCZ	1	116-0538	010		010
	15", 326 – 405 TCZ	1	116-0537	010		010
	15", 444 TCZ +	1	116-0539	010		010

\*MACHINED FOR OPTIONAL IMPELLER WEAR RINGS, ITEMS 14 & 15  
 (XL = EXTRA LARGE BORE)

## WARRANTY

Seller warrants equipment (and its component parts) of its own manufacture against defects in materials and workmanship under normal use and service for one (1) year from the date of installation or start-up, or for eighteen (18) months after the date of shipment, whichever occurs first. Seller does not warrant accessories or components that are not manufactured by Seller; however, to the extent possible, Seller agrees to assign to Buyer its rights under the original manufacturer's warranty, without recourse to Seller. Buyer must give Seller notice in writing of any alleged defect covered by this warranty (together with all identifying details, including the serial number, the type of equipment, and the date of purchase) within thirty (30) days of the discovery of such defect during the warranty period. No claim made more than 30 days after the expiration of the warranty period shall be valid. Guarantees of performance and warranties are based on the use of original equipment manufactured (OEM) replacement parts. Seller assumes no responsibility or liability if alterations, non-authorized design modifications and/or non-OEM replacement parts are incorporated. If requested by Seller, any equipment (or its component parts) must be promptly returned to Seller prior to any attempted repair, or sent to an authorized service station designated by Seller, and Buyer shall prepay all shipping expenses. Seller shall not be liable for any loss or damage to goods in transit, nor will any warranty claim be valid unless the returned goods are received intact and undamaged as a result of shipment. Repaired or replaced material returned to customer will be shipped F.O.B., Seller's factory. Seller will not give Buyer credit for parts or equipment returned to Seller, and will not accept delivery of any such parts or equipment, unless Buyer has obtained Seller's approval in writing. The warranty extends to repaired or replaced parts of Seller's manufacture for ninety (90) days or for the remainder of the original warranty period applicable to the equipment or parts being repaired or replaced, whichever is greater. This warranty applies to the repaired or replaced part and is not extended to the product or any other component of the product being repaired. Repair parts of its own manufacture sold after the original warranty period are warranted for a period of one (1) year from shipment against defects in materials and workmanship under normal use and service. This warranty applies to the replacement part only and is not extended to the product or any other component of the product being repaired. Seller may substitute new equipment or improve part(s) of any equipment judged defective without further liability. All repairs or services performed by Seller, which are not covered by this warranty, will be charged in accordance with Seller's standard prices then in effect.

THIS WARRANTY IS THE SOLE WARRANTY OF SELLER AND SELLER HEREBY EXPRESSLY DISCLAIMS AND BUYER WAIVES ALL OTHER WARRANTIES EXPRESSED, IMPLIED IN LAW OR IMPLIED IN FACT, INCLUDING ANY WARRANTIES OF MERCHANTABILITY OR FITNESS FOR A PARTICULAR PURPOSE. Seller's sole obligation under this warranty shall be, at its option, to repair or replace any equipment (or its component parts) which has a defect covered by this warranty, or to refund the purchase price of such equipment or part. Under the terms of this warranty, Seller shall not be liable for (a) consequential, collateral, special or liquidated losses or damages; (b) equipment conditions caused by normal wear and tear, abnormal conditions of use, accident, neglect, or misuse of said equipment; (c) the expense of, and loss or damage caused by, repairs or alterations made by anyone other than the Seller; (d) damage caused by abrasive materials, chemicals, scale deposits, corrosion, lightning, improper voltage, mishandling, or other similar conditions; (e) any loss, damage, or expense relating to or resulting from installation, removal or reinstallation of equipment; (f) any labor costs or charges incurred in repairing or replacing defective equipment or parts, including the cost of reinstalling parts that are repaired or replaced by Seller; (g) any expense of shipment of equipment or repaired or replacement parts; or (h) any other loss, damage or expense of any nature.

The above warranty shall not apply to any equipment which may be separately covered by any alternate or special warranties.

**PERFORMANCE:** In the absence of Certified Pump Performance Tests, equipment performance is not warranted or guaranteed. Performance curves and other information submitted to Buyer are approximate and no warranty or guarantee shall be deemed to arise as a result of such submittal. All testing shall be done in accordance with Seller's standard policy under Hydraulic Institute procedures.

**LIABILITY LIMITATIONS:** Under no circumstances shall the Seller have any liability under the Order or otherwise for liquidated damages or for collateral, consequential or special damages or for loss of profits, or for actual losses or for loss of production or progress of construction, regardless of the cause of such damages or losses. In any event, Seller's aggregate total liability under the Order or otherwise shall not exceed the contract price.

**ACTS OF GOD:** Seller shall in no event be liable for delays in delivery of the equipment or other failures to perform caused by fires, acts of God, strikes, labor difficulties, acts of governmental or military authorities, delays in transportation or procuring materials, or causes of any kind beyond Seller's control.

**COMPLIANCE WITH LAW:** Seller agrees to comply with all United States laws and regulations applicable to the manufacturing of the subject equipment. Such compliance shall include: The Fair Labor Standards Acts of 1938, as amended; Equal Employment Opportunity clauses of Executive Order 11246, as amended; Occupational Safety and Health Act of 1970 and the standards promulgated thereunder, if applicable. Since compliance with the various Federal, State, and Local laws and regulations concerning occupational health and safety, pollution or local codes are affected by the use, installation and operation of the equipment and other matters over which Seller has no control, Seller assumes no responsibility for compliance with those laws and regulations, whether by way of indemnity, warranty, or otherwise. It is incumbent upon the Buyer to specify equipment which complies with local codes and ordinances.



**AURORA®**

800 Airport Road  
North Aurora, Illinois 60542

630-859-7000

[www.aurorapump.com](http://www.aurorapump.com)